

880mm INTEGRATED DOWNDRAFT RANGEHOOD with REMOTE CONTROL

SDD2ELEMIC88

valentina
collection |  **Sirius**



Rangehood type	Integrated Downdraft
Control	Separate remote location with Remote Control
Speed settings	4
Ducting diameter	200mm
Extraction type	Offboard motor
Green Energy Motor	SEM71, SEM81
Filter	Aluminium mesh filter
Safety features	Auto-stop
Lighting	Light strip
Auto Run-on Timer	Yes
Electrical requirement	10A
Dimensions (fully extended) (mm)	W833 x D97 x H300
Weight	40kg
Warranty	3 years (6 years when Sirius ducting is used)



**INDUCTION
SAFE**

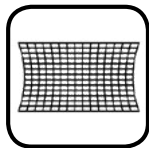

**ALUMINIUM
MESH FILTER**



**CAN BE
RECYCLED**



LIGHT STRIP



**EUROPEAN-
MADE MOTOR**



**HANDCRAFTED
IN ITALY**

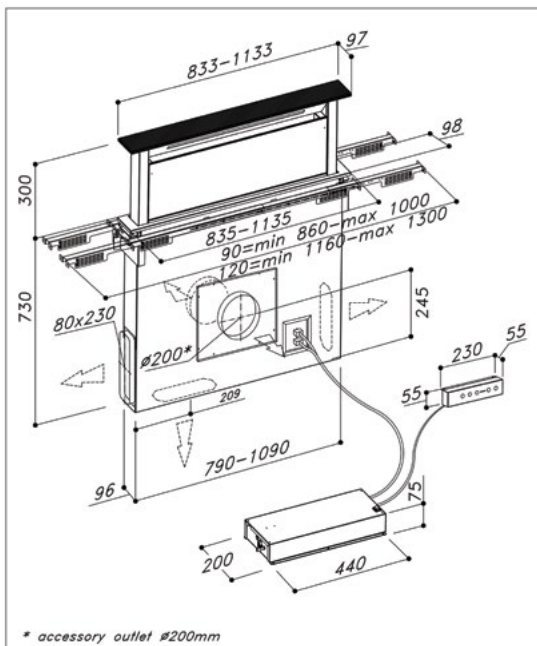

*Outdoor offboard motors have a marine grade finish as standard for added resistance to coastal weather elements.

Ducting options

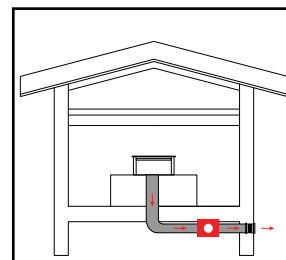

External venting
(SEM8 shown)

- Can be used with SEM71 and SEM81 or Front Mounted DDFMEL.
- Use semi-rigid or rigid ducting, not fully flexible foil ducting.
- Fewer bends means a quieter and more powerful extraction.
- Extra 3 years warranty when Sirius ducting is used (total 6 years).
- See [support page](#) on Sirius website for installation videos and FAQs.

WARNING: technical specifications and product sizes can be varied by the manufacturer, without notice. Cut outs for appliances should only be by physical product measurements. The above information is indicative only.

Distributed by Arisit Pty Ltd

40-50 Mark Anthony Drive, Dandenong South VIC 3175

Ph: 1300 762 219

Fax: 03 9768 0838

Website: www.arisit.com

www.siriusbrand.com

06/2023