



**Congratulations on your purchase!
Thank you for choosing a Sirius product.**

SDD2ELEMIC
INTEGRATED DOWNDRAFT INSTALLATION
INSTRUCTIONS FOR
SEM 11, SEM 21, SEM 71, SEM 81 & DDFMEL motors

SDD2ELEMIC58
SDD2ELEMIC88
SDD2ELEMIC118

EAN #9351116005375
EAN #9351116005382
EAN #9351116005399

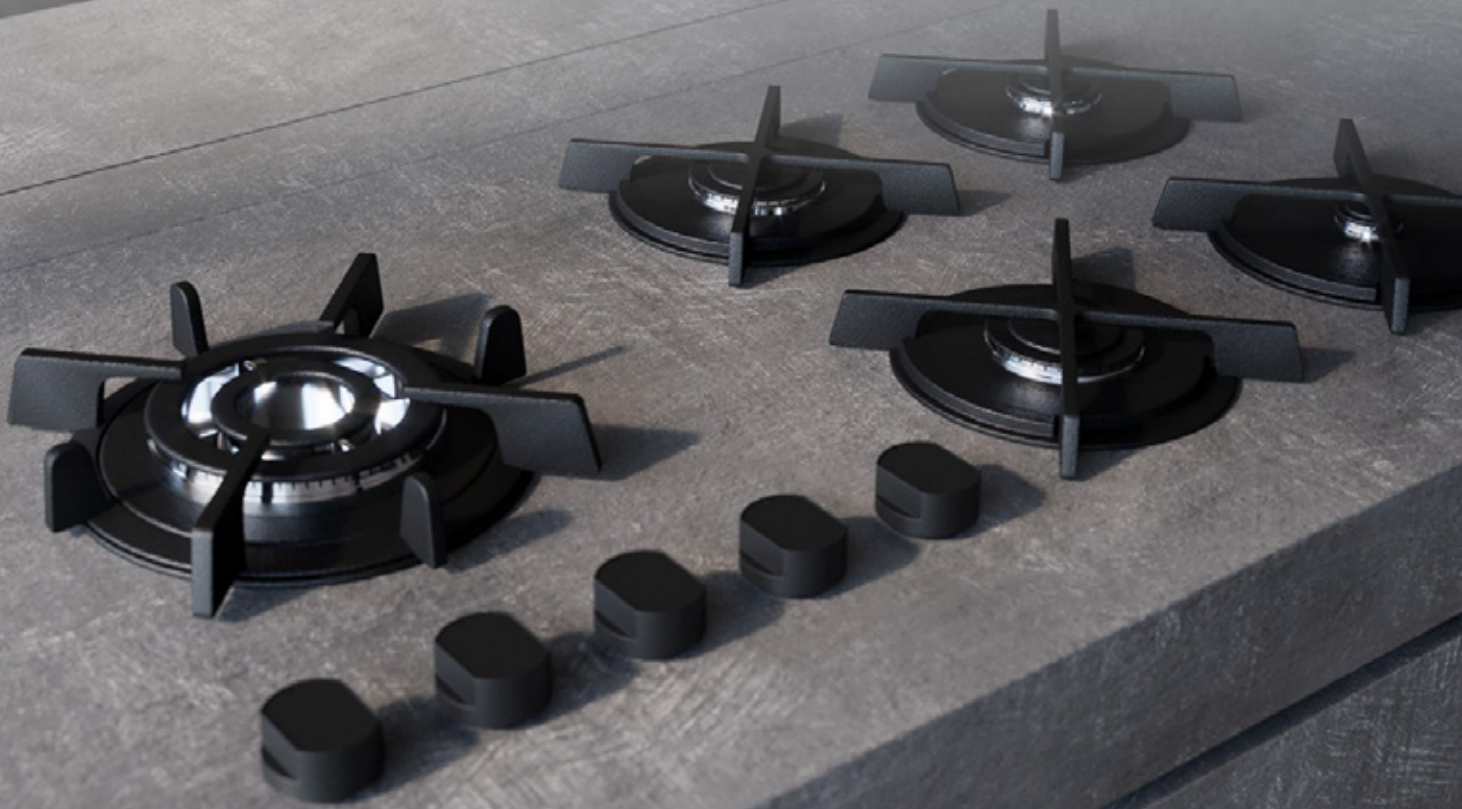

BEFORE YOU INSTALL - DUCTING INFORMATION	4
TO THE ATTENTION OF THE USER	5
INSTALLATION GUIDELINES	5
APPLIANCE DIAGRAMS	6
PRE-INSTALLATION CHECKS	7
INSTALLING THE RANGEHOOD	8
FOR SEM 71 AND SEM 81 200MM SIDE OR BOTTOM VENTING	16
FOR SEM 71, AND SEM 81 200MM FRONT OR REAR VENTING	18
FOR DDFMEL 150MM BOTTOM VENTING	19
DUCTING FROM MOTOR TO VENT SEM 8 ONLY)	20
ELECTRICAL CONNECTION	20
HOW THE RANGEHOOD WORKS	22
CLEANING THE RANGEHOOD	27
TROUBLESHOOTING	28
REPLACING THE LIGHT	29
PARTS LIST	31
WIRING DIAGRAM	34
WARRANTY INFORMATION	35

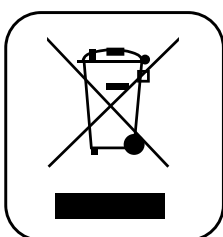

The symbol on the product or on its packaging indicates that this product may not be treated as house-hold waste. Instead it shall be handed over to the applicable collection point for the recycling of electrical and electronic equipment. By ensuring this product is disposed of correctly, you will help prevent potential negative consequences for the environment and human health, which could otherwise be caused by inappropriate waste handling of this product. For more detailed information about recycling of this product, please contact your local city office, your household waste disposal service or the shop where you purchased the product. This appliance is marked according to the European directive 2002/96/EC on waste electrical and electronic equipment (WEEE).

BEFORE YOU INSTALL - DUCTING INFORMATION

Sirius warranty covers only Sirius product. If you choose to install a non-Sirius branded accessory such as flexible ducting, Sirius will only warrant the rangehood and motor. If installation is found to be the cause of failure or issue then charges will apply for service and parts.

Flexible ducting is not permitted under any circumstances. Flexible ducting has been found to increase noise levels, increase vibration and reduce airflow. Sirius Semi-rigid or solid ducting can be used in lieu. There is a range available to suit any application.



The appliance must be installed and connected to the power supply only by a qualified technician.

- There should be adequate ventilation of the room when the rangehood is used at the same time as appliances burning gas or other fuels (not applicable to appliances that only discharge the air back into the room)
- The details concerning the method and frequency of cleaning
- There is a fire risk if cleaning is not carried out in accordance with the instructions;
- Do not flambé under the range hood;
- CAUTION: Accessible parts may become hot when used with cooking appliances.

Ducting available at www.siriusbrand.com

6 Year Warranty when Sirius Ducting is used. Full replacement warranty on parts and labour. See website for terms & conditions.

A reduction in the duct diameter from stated ducting size will void warranty.

If you are in doubt about the ducting, please contact Sirius on 1300 762 219 prior to installation

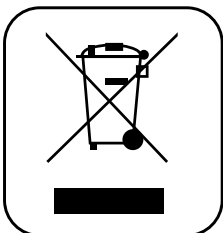

The symbol on the product or on its packaging indicates that this product may not be treated as household waste. Instead it shall be handed over to the applicable collection point for the recycling of electrical and electronic equipment. By ensuring this product is disposed of correctly, you will help prevent potential negative consequences for the environment and human health, which could otherwise be caused by inappropriate waste handling of this product. For more detailed information about recycling of this product, please contact your local city office, your household waste disposal service or the shop where you purchased the product. This appliance is marked according to the European directive 2002/96/EC on waste electrical and electronic equipment (WEEE).

TO THE ATTENTION OF THE USER

This rangehood is designed to be ducted to outside the house.



Keep these instructions for use with the appliance. If the appliance should be sold or passed on to others, make sure that the instructions are passed on with it. We thank you for taking note of these suggestions before installing and using the appliance. They have been written for your personal safety and the safety of others.

SAFETY INSTRUCTIONS

These hoods have been designed for personal use in the home. The appliance must be used by adults. Make sure that the appliance is out of reach of children and that they do not use it to play with. Make sure that children do not operate the controls.

- When the appliance is delivered, check the overall appearance of the packaging. **Check PARTS LIST on page 31-33 for all included parts prior to discarding packaging.**

Any remarks should be written on the delivery coupon, of which you keep a copy.

Your appliance is designed for normal domestic use. It is not designed for commercial or industrial use, or for purposes other than those for which it was designed.

- Any consequences of or damage from incorrect installation or incorrect use of the appliance will not be covered by the manufacturer's guarantee.
- Do not ever change or try to change the characteristics of this appliance. This would be a danger. Repairs must be performed only by an authorised technician.
- Always disconnect the hood before carrying out cleaning or maintenance operations.
- Adequately ventilate the room when a rangehood and other appliances, powered by energy other than electricity, are used simultaneously, so that the hood does not suck any combustion fumes.
- It is not allowed to cook food over open flames (flambé) or operate gas hobs without pots or pans on them under the hood itself (the flames sucked into the hood might damage the appliance).
- Frying under the appliance must be done under constant supervision as hot oils and fats may ignite.
- Respect the guidelines for cleaning and replacement of grease filters. Accumulated deposits of grease are a fire hazard.

INSTALLATION GUIDELINES FOR ELECTRIC HOB

Minimum 20mm to 60mm maximum distance between liner of downdraft and edge of hob.

INSTALLATION GUIDELINES FOR GAS COOKTOP APPLICATIONS

- A minimum 150mm space between liner of downdraft, and edge of hob burner
- For the downdraft to operate at a premium, the distance between the downdraft opening and the furthest burner shall not exceed 650mm.
- Distance between the burners on the side closest to the downdraft shall not be closer than 165mm.

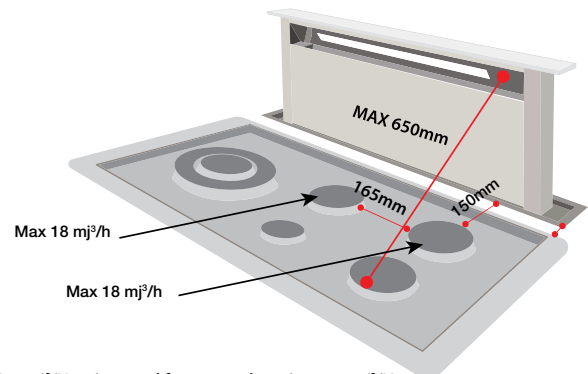

- Max mj³/H rating total for gas cooktop is 58.32 mj³/H

- This appliance must not be used over cooktops powered by wood or coal or in any case, over cook tops with power levels that could damage the appliance.
- Never use steam or high-pressure devices for cleaning your hood (regulations regarding electrical safety).
- Never use the rangehood without the grease filters.
- The minimum distance between the Downdraft (closed) and the surface above it must be at least 800 mm. Cabinetry lower than 800mm will prevent the removal of the downdraft should servicing be required.
- When handling the downdraft, never put your hands in the field of action of the extractable unit.
- Downdraft must be removable for serviceability.

At Sirius, we are constantly seeking to improve our products. We reserve the right to modify their technical, functional, or aesthetic characteristics deriving from their upgrading.

Motors manufactured and approved by Sirius only are to be used at all times. Failure to comply with this will result in the forfeit of the manufacturer warranty.

The air collected must not be conveyed into a flue used for smoke or fumes from appliances powered by anything other than electricity (central heating systems, bathroom and toilet exhausts, etc.). As far as discharging exhaust air is concerned, please follow the guidelines given by competent authorities.

APPLIANCE DIAGRAMS

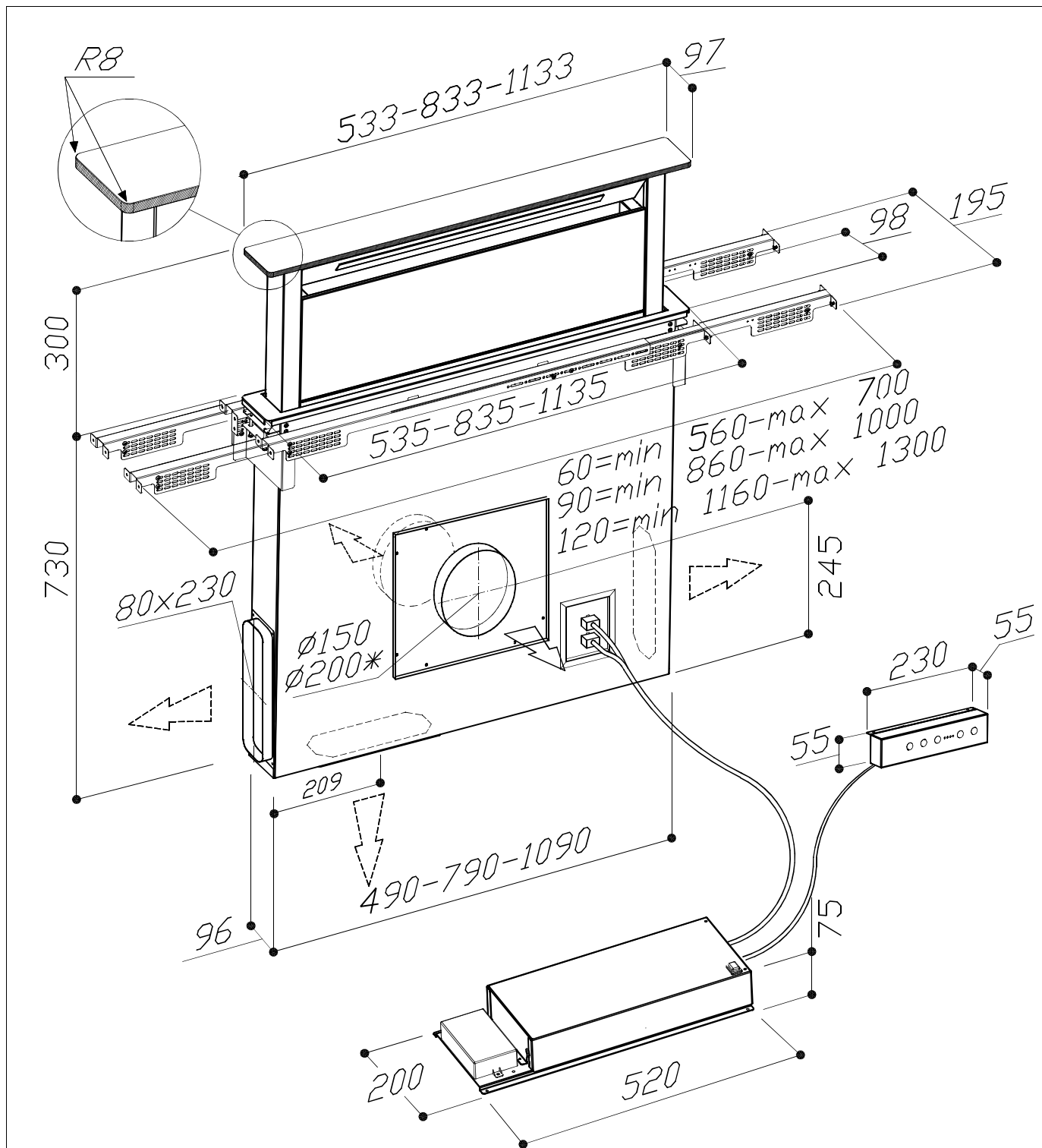

* accessory outlet $\varnothing 200$ mm

Rectangular opening: 100x837/1137 (mm)

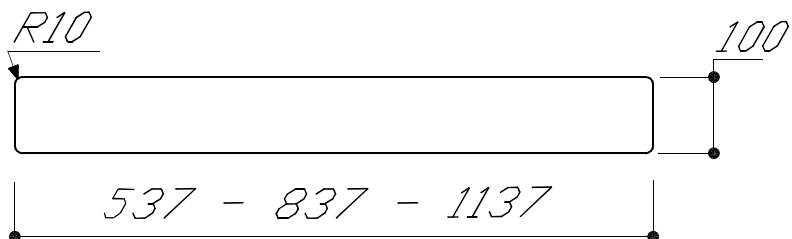



Check PARTS LIST on page 31-33 for all included parts prior to discarding packaging.

PRE-INSTALLATION CHECKS

Plug the main control box into a 10 amp GPO and connect the motor by removing the 4 screws on the black section of the control box. Connect the corresponding coloured wires to the connections. Plug in the manual hand control box and test that the unit raises and lowers and that the motor is operational. If the unit works as it should, disconnect this and proceed with installation



Installation must comply with the regulations in force regarding the ventilation of enclosed environments. In particular, discharged air must not be conveyed into a duct used for fumes discharge or discharge from appliances using gas or other combustible materials. Air cannot be ducted into roof space.

The use of discontinued ducts is not allowed without the approval of a qualified technician.

BEFORE YOU INSTALL

Sirius warranty covers only Sirius product. If you choose to install a non-Sirius branded accessory such as flexible ducting, Sirius will only warrant the hood and motor. If installation is found to be the cause of failure or issue then charges will apply for service and parts.

Flexible ducting is not permitted under any circumstances. Flexible ducting has been found to increase noise levels, increase vibration and reduce airflow. Sirius Semi-rigid or solid ducting can be used in lieu. There is a range available to suit any application.

Using Sirius ducting gives you an additional 3 years warranty making a total of 6 years.

SEM offboard motors have a 10 year warranty.

Available at www.siriusbrand.com

**A reduction in the duct diameter from stated ducting size will void warranty.
If you are in doubt about the ducting, please contact Sirius on 1300 762 219 prior to installation.**

INSTALLING THE RANGEHOOD



Certain installations will require ducting provisions to be completed prior to this stage. See Pages 16-19 for applicable motor installations

- Before carrying out the appliance installation, please check that all components are not damaged, in such a case contact your retailer and do not carry out any installation operation. Before the installation of the downdraft, please remove the safety piece you can see in the picture (**Fig. 1a**). Leave all other protective tape in place at this point. Furthermore, please read carefully all of the following installation instructions.
- Use Sirius ducting with a maximum length of 7 metres to the motor.
- Limit the number of elbows in the ducting, since each elbow reduces the air capacity of 1 linear meter. (Ex: if you use no. 2 x 90° elbows, the length of piping should not exceed 5 meters).
- Avoid abrupt direction changes. (Optimum angle 45° when required)
- Use a 200mm ducting - constant diameter pipe for the whole length.

Use ducting approved by standards enforced - see www.siriusbrand.com.au for approved ducting. The manufacturer shall not be deemed responsible for air capacity or noise problems caused by failure to comply with the above instructions and no warranty on the product shall be provided.

STEP 1:

Refer to cutout dimensions required per unit as they vary for each unit.

1. Before making the cutout, check that there are no structural or other parts inside the cabinet where the appliance is to be placed which could hinder a proper installation. Check that the dimensions of the downdraft and the cooktop are compatible with the cabinet so that the installation can be carried out properly.
2. Make a rectangular cutout, with a radius of 10 on each corner, at the rear of the cooktop location:
 - **537mm x 100mm** for the 580mm model
 - **837mm x 100mm** for the 880mm model
 - **1137mm x 100mm** for the 1180mm model. (**Fig. 2**)
3. Lower the downdraft section into the cut out to ensure clearance is sufficient for installation. (**Fig. 1b**)



Front 200mm duct adapter will need to be removed to allow the unit to clear



Technical specifications and product sizes can be varied by the manufacturer without notice. Cut out dimensions are indicative only and physical measurement should be taken as a precautionary measure to ensure no issues arise with fitment.



The cutout MUST be done by a professional. It is vital that the cutout is perfectly made so as not to have fitment issues with the product. The cutout section can be used (thickness dependent, Min. 10mm - 32mm Max.) as the top of the downdraft so it matches the benchtop perfectly.

Should these instructions be ignored, the manufacturer or agent will not be held responsible for any damage caused to either downdraft, benchtops or cabinetry.

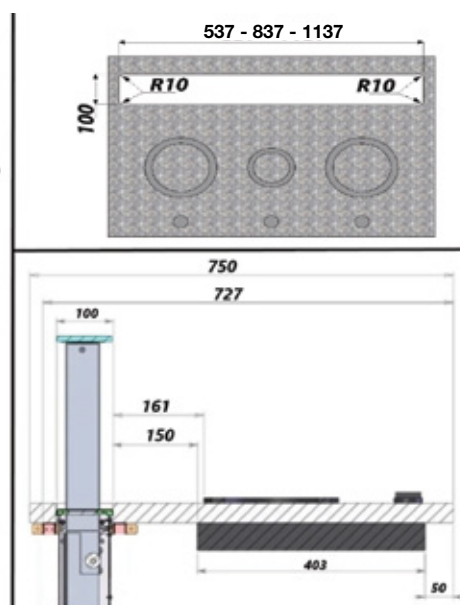
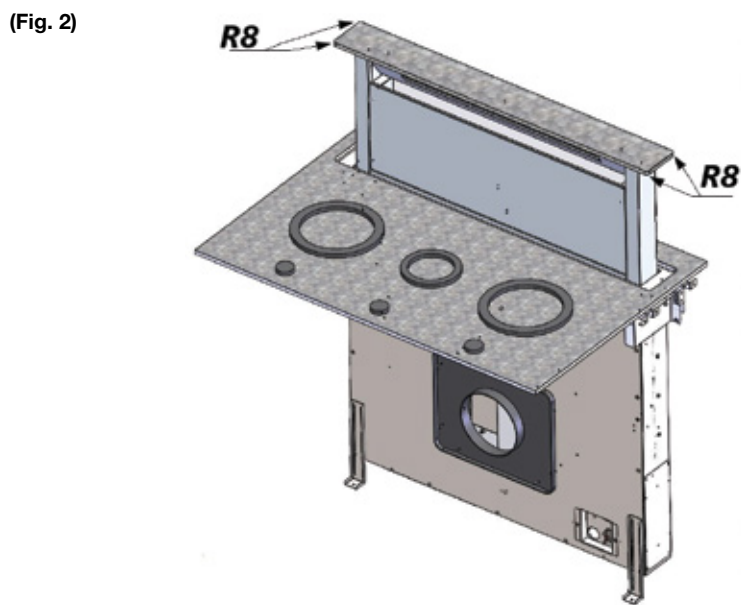
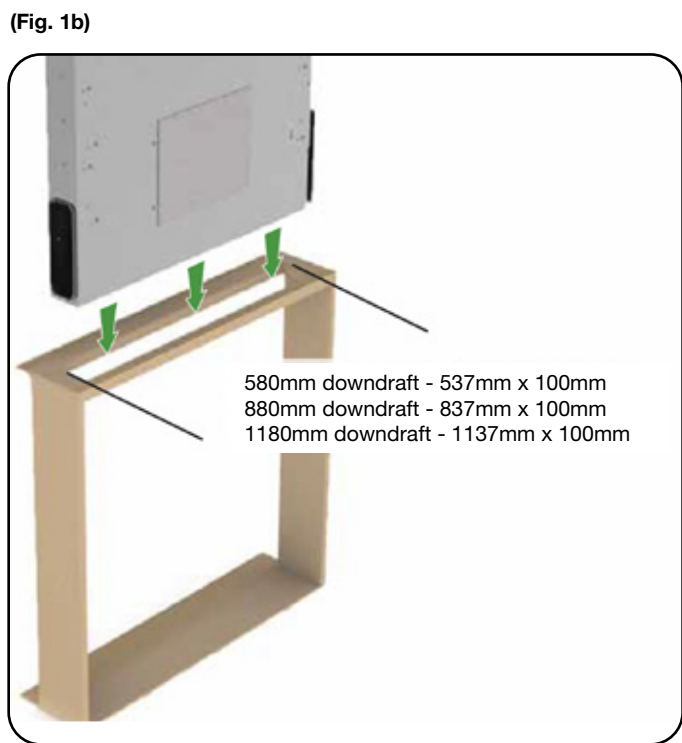
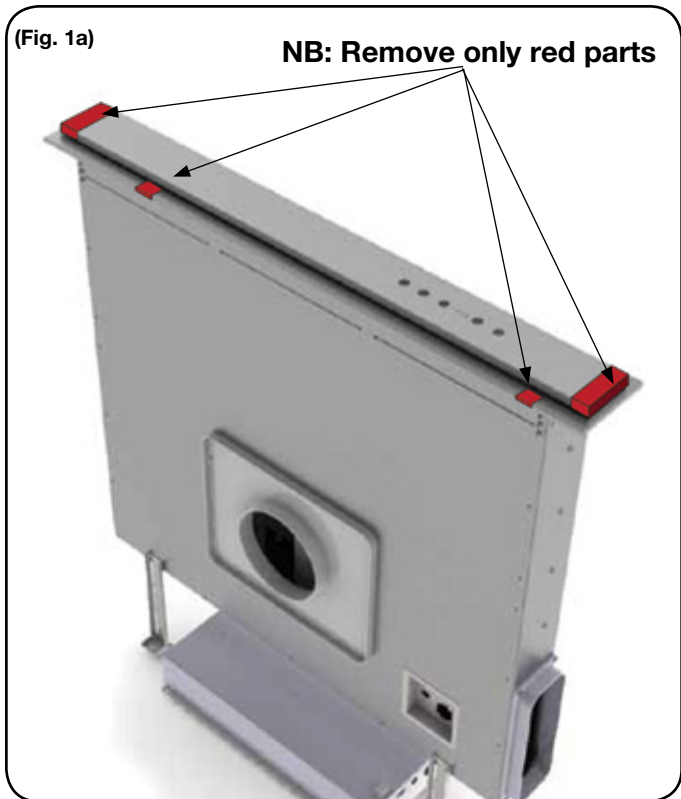

Internal Support Frame Assembly

4. Take the accessories supplied in the package (A-B-C-D see Fig 5)

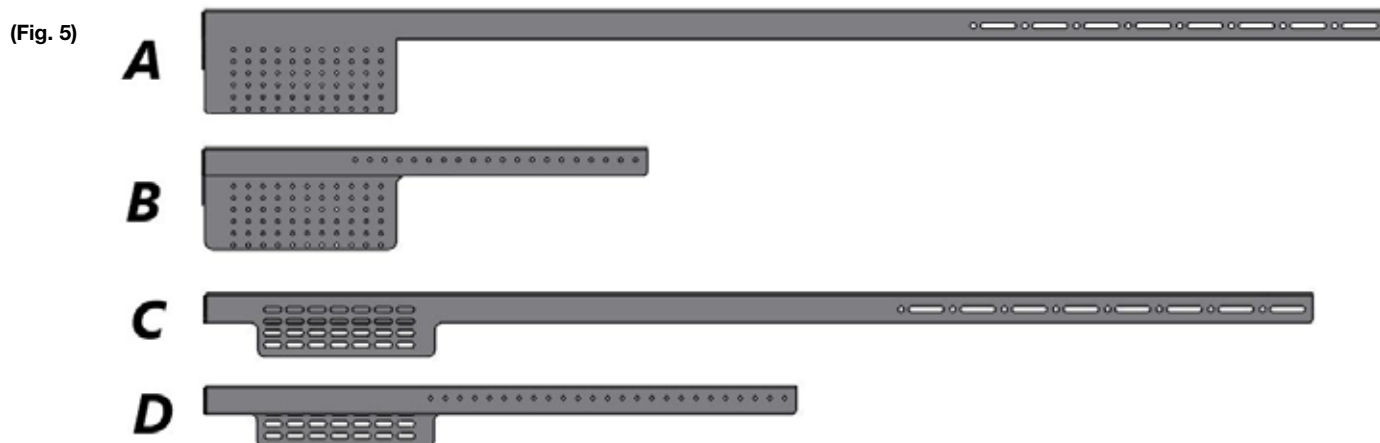

Slot the two corresponding part A with B and C with D together (fig 4).

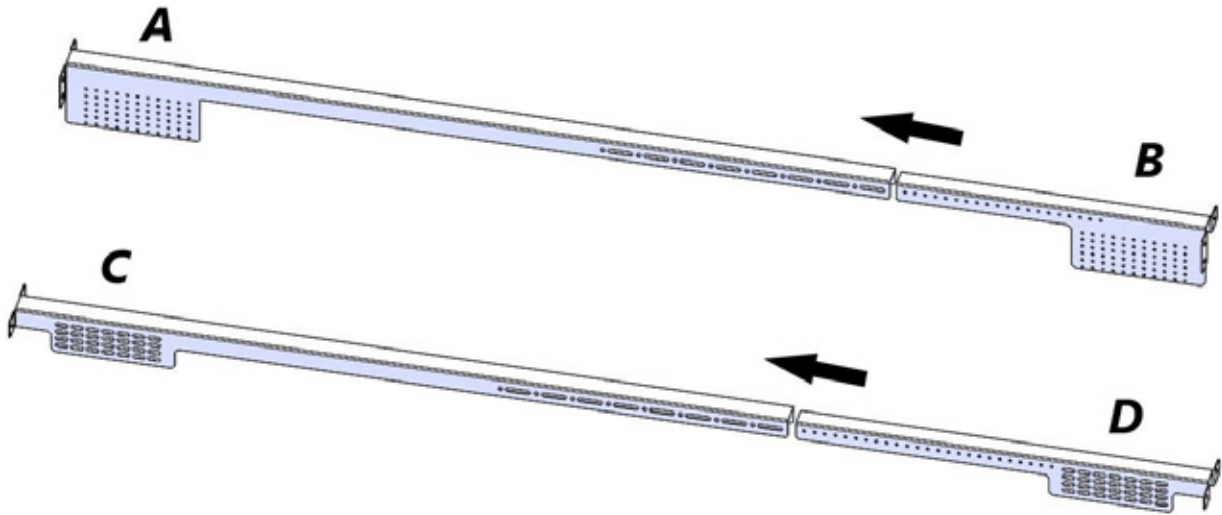

(Fig. 4)

5. Measure the desired length these two sections need to be in correspondence with the internal cabinetry (Fig. 5). Note: Min 860mm – Max 1000mm for **880** units and Min 1160mm – Max 1300mm for **1180** units. Secure the two sections A and B + C and D together using 4 x 10mm supplied screws (Fig. 6)

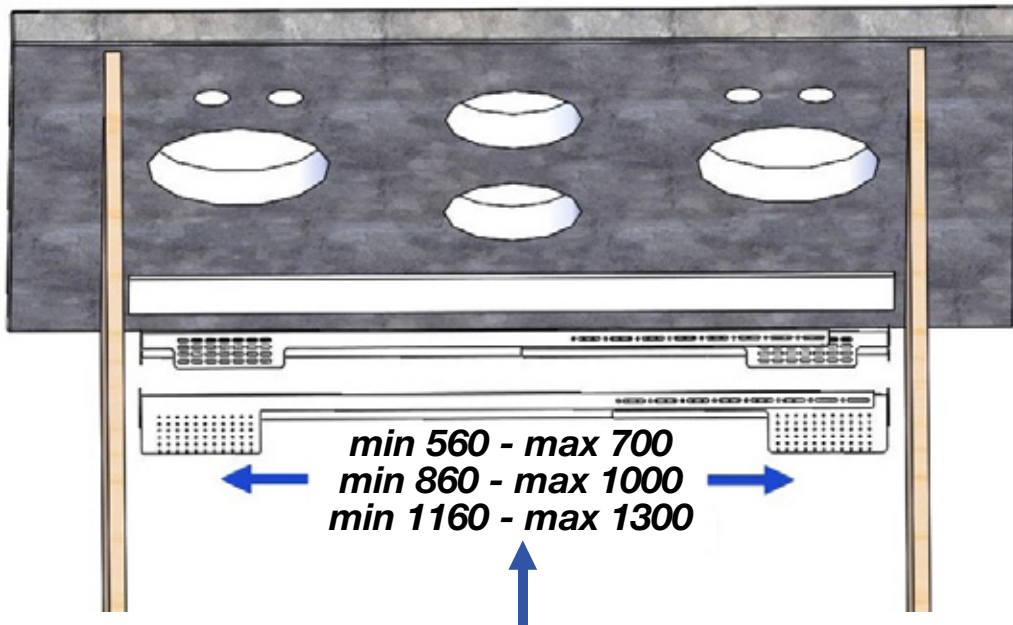

(Fig. 5)

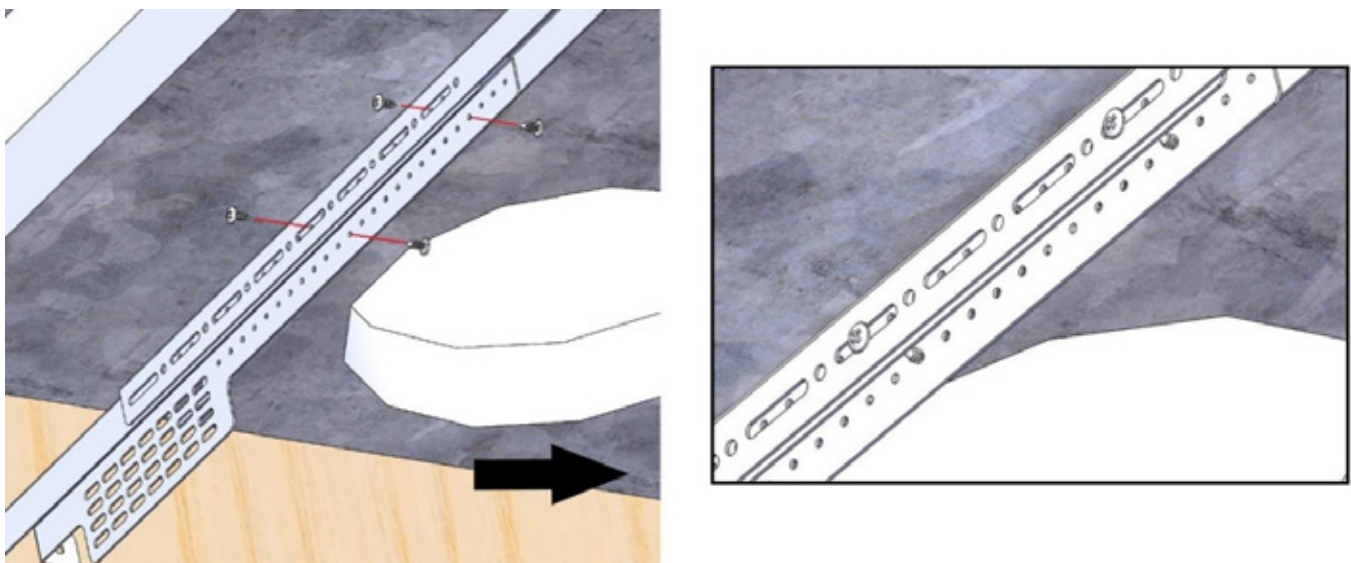

(Fig. 6)

Line up the edges of the of the two sections of frame with the benchtop cutout and secure in place as per (Fig. 7), (Fig. 8) & (Fig. 9). Note: The screws put in place in (Fig. 6) cannot sit inside the width of the benchtop cutout as they will obstruct the downdraft body when lowered into place.

Warning: the accessories must be fixed in correspondence with the rectangular hole (each pair on each long side) at a maximum distance of 107mm (Fig. 7).

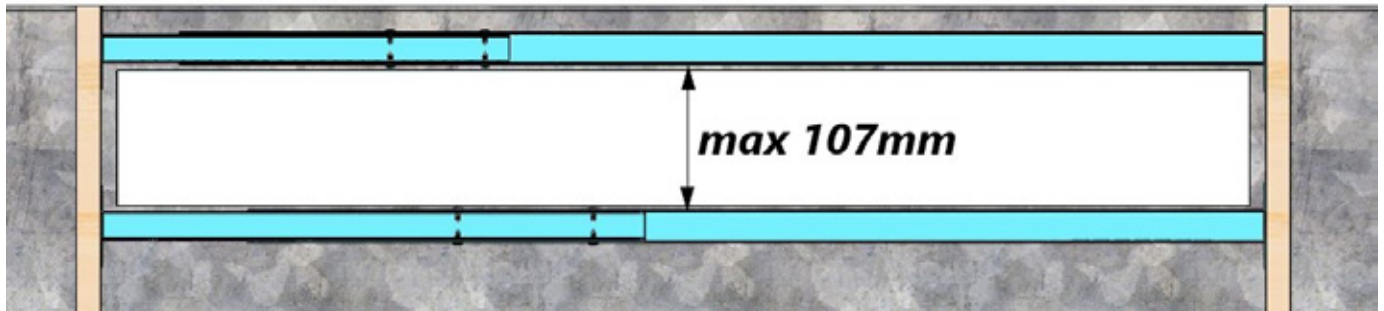

(Fig. 7)

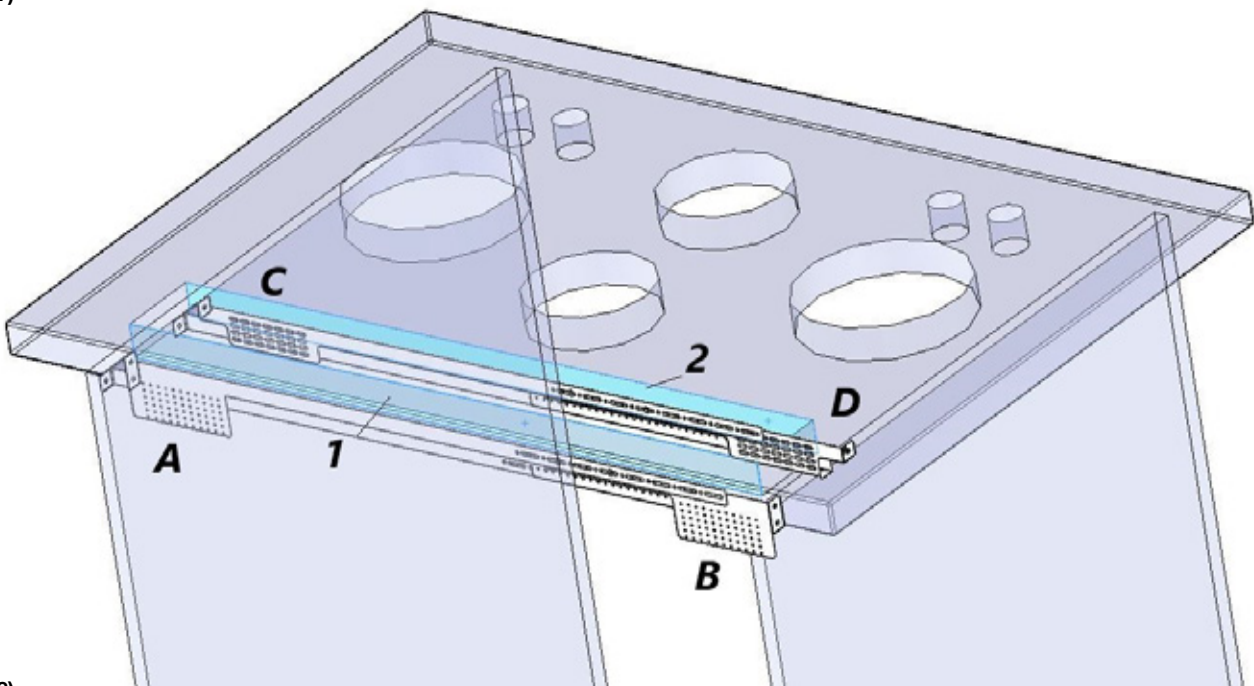

(Fig. 8)

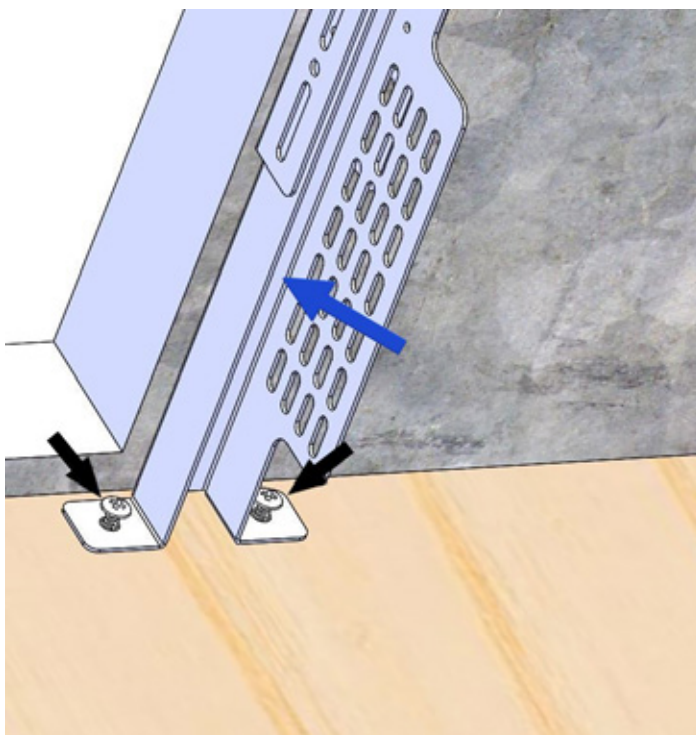

(Fig. 9)

Support and Height Adjustable Brackets (Fig. 10)

These brackets are fixed in between the horizontal length brackets and are put into position as per (Fig.11) Insert one at either end ensuring that the slotted holes and the round holes correspond with the horizontal bracket allowances. Slotted holes of parts E & F will be at the rear side (furthest from cooktop) and the round holes to the front side (nearest to cooktop). (Fig 11)

Fasten in place with two x 10mm Screws on either side of 'E&F' as per (Fig.12)

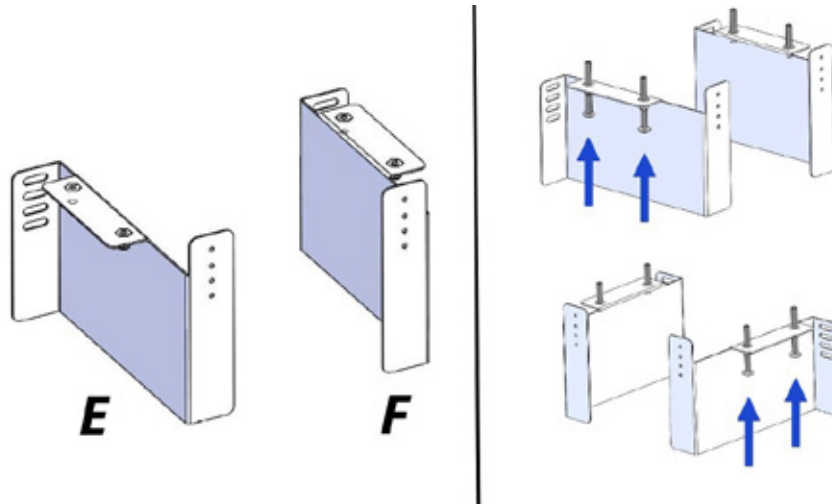

(Fig. 10)

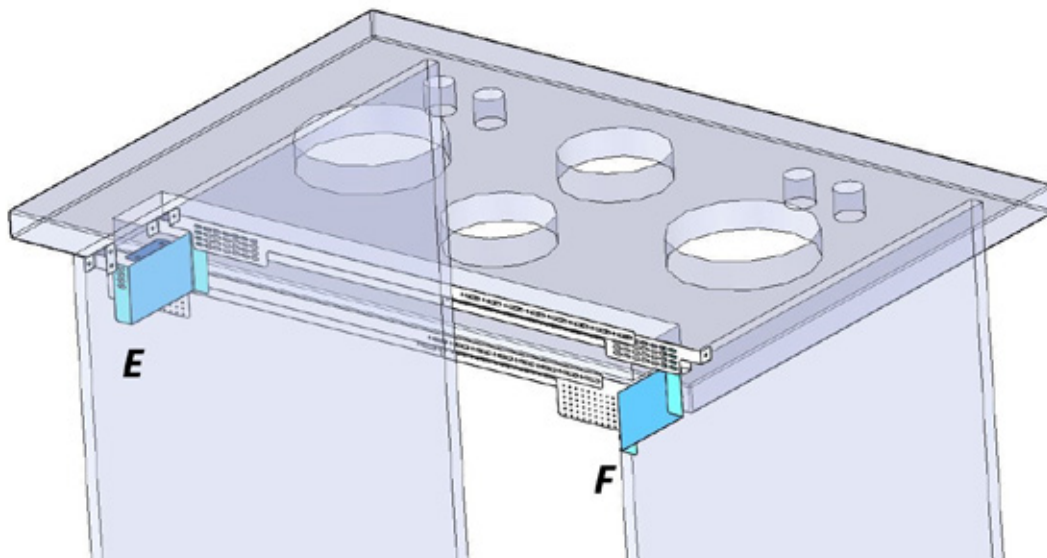

(Fig. 11)

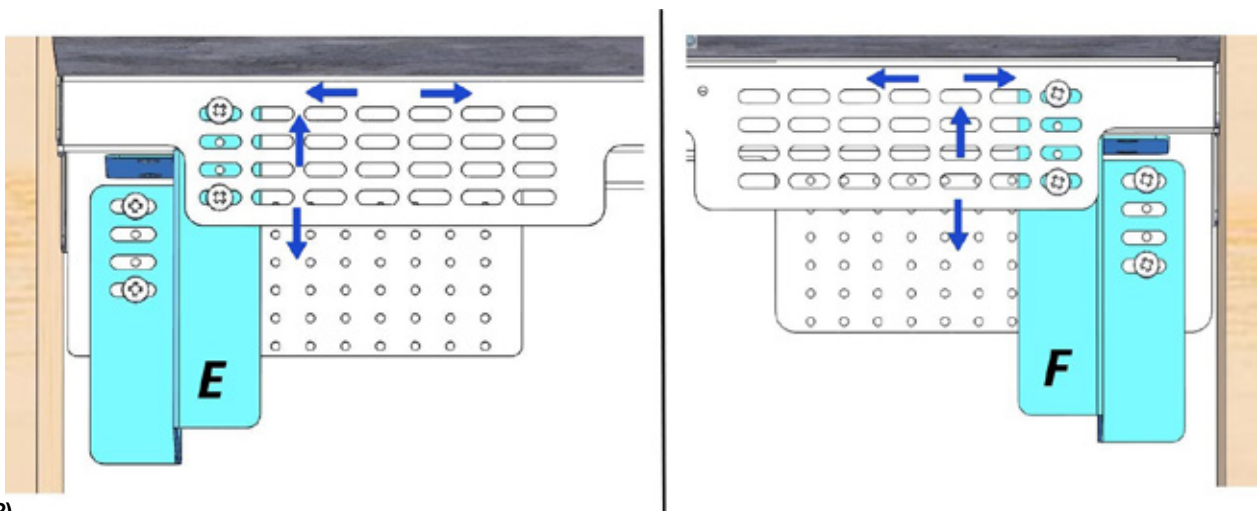

(Fig. 12)

Note: The bracketing system has several slots to allow adjustments of the downdraft both on the basis of its width (left - right) and on the thickness of the top to be glued on the downdraft (top - bottom) Fig. 12

Support and Height Adjustable Brackets (Fig. 10)

Remove the 200mm Diameter Front Section by removing the screws securing it in place. If not using this outlet for ducting, replace with the solid flat cover plate (SPS-75059000082) and fix back in place. If ducting from this outlet, the connection can be put back on once the downdraft is in its set position. (Fig. 14a). If using the bottom outlet to vent the range hood out it is advised to fit Part 'B' (SPS-51070102735) to the unit at this stage as fitting it after the unit is lowered may be difficult.

7. Install the downdraft in the hole made, inserting it from above (Fig. 14b), (note, two people will be required for this step as it is quite heavy).

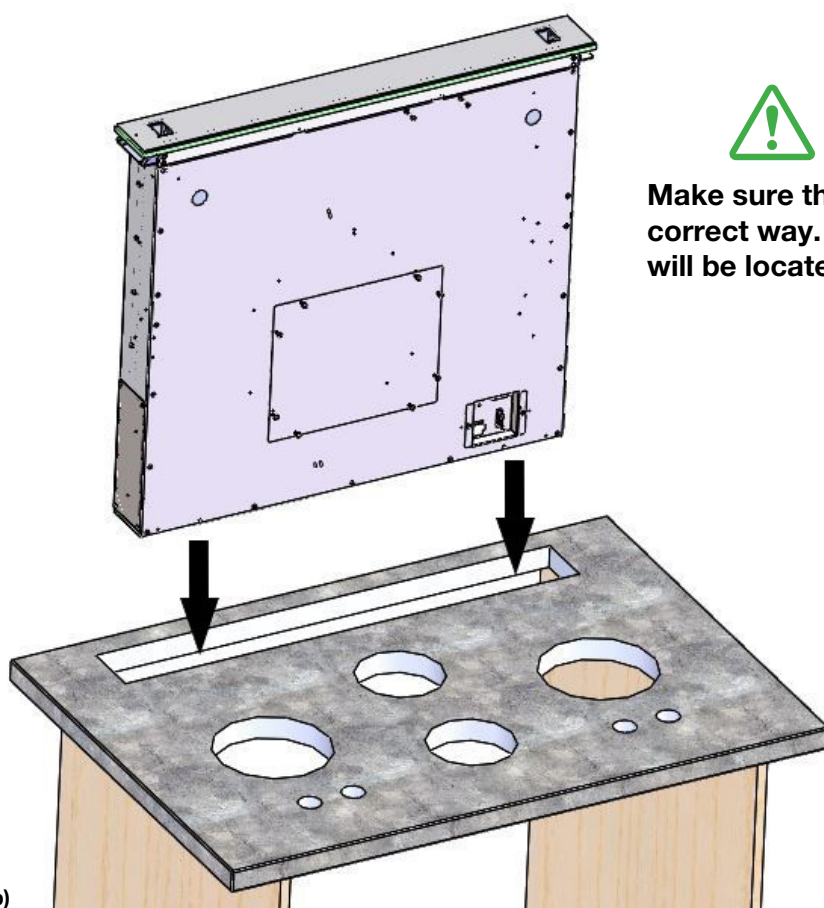
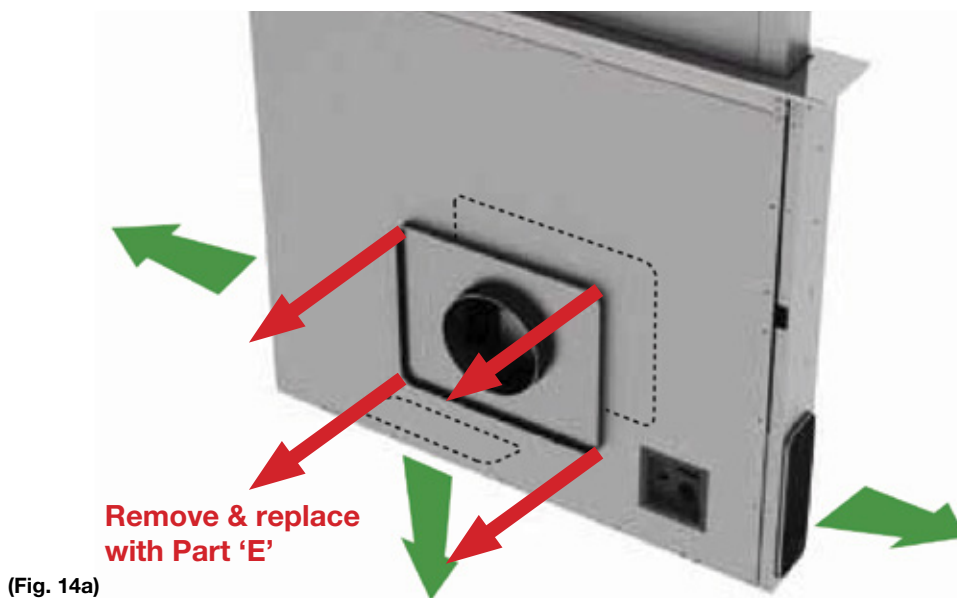

NOTE



Make sure the unit is around the correct way. Electrical connections will be located as per diagram.

(Fig. 14b)

The downdraft will sit onto the height adjustable brackets 'E & F' at either end of the cutout.

Adjusting the height of the benchtop insert section

The height of the downdraft insert can be adjusted up and down to ensure a seamless flush finish with the benchtop. Using a Phillips head screwdriver, adjust the threaded screws up or down to according to the desired thickness of the insert. (Fig. 15)

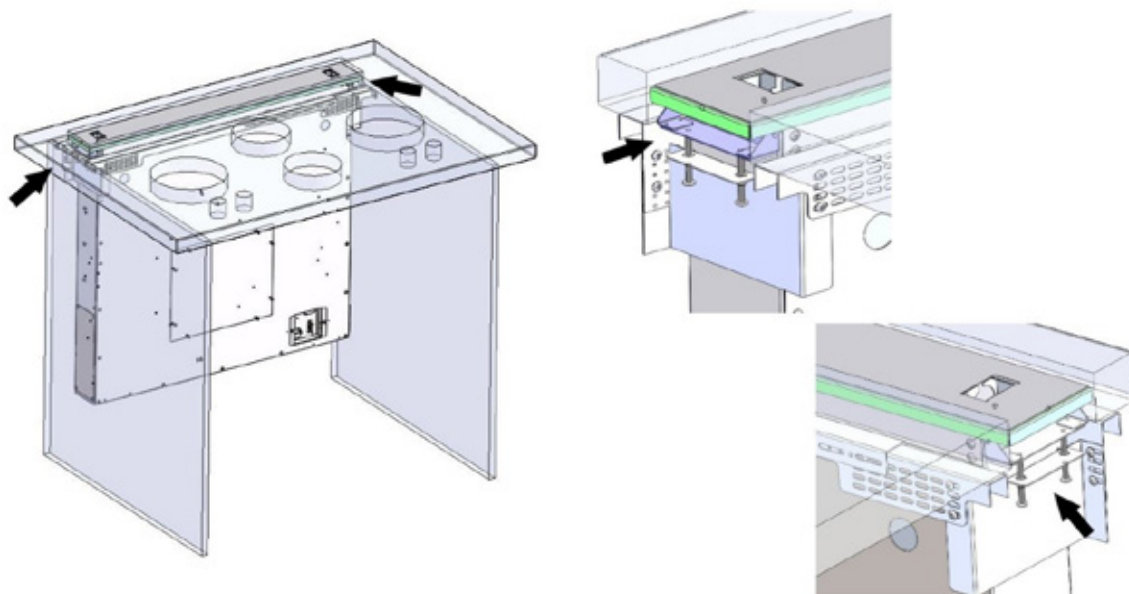

(Fig. 15)

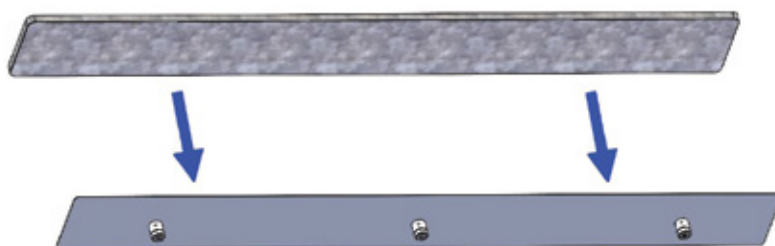

(Fig. 16.1)

To determine the correct line-up of the downdraft, place the part (glued in the previous step) inside the rectangular niche, making the magnets (G) coincide with the seat (H) and check that the two surfaces are perfectly at the same level (fig. 16.2)

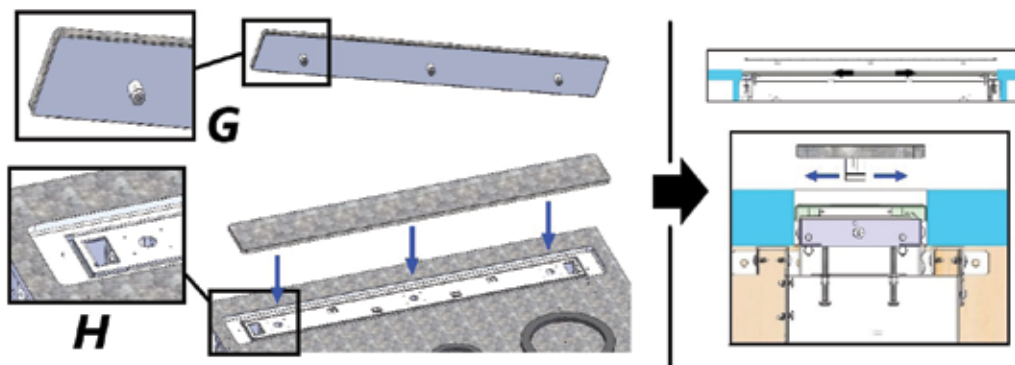

(Fig. 16.2)

Note: Any of the screws on the body of the downdraft can be used to secure these brackets in place.

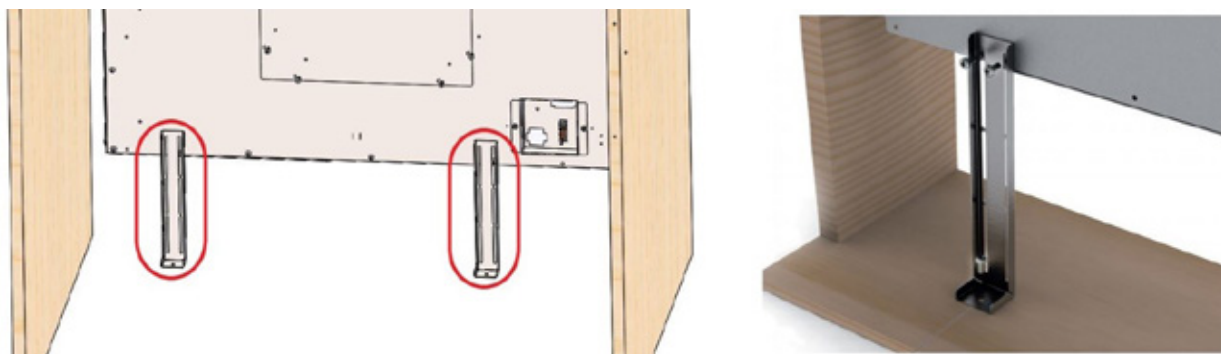

(Fig. 17)

Having verified the correct position and stability of the product, proceed to glue the additional surface on the top of the downdraft.

8. After completion of the downdraft installation, the push button control buttons need to be fitted. These can be positioned below the overhang of the bench top or recessed into the cabinetry (see fig.18A for central installation, fig.18B for lateral installation). Before fixing the push-button panel, ensure that the controls do not prevent any doors from closing.

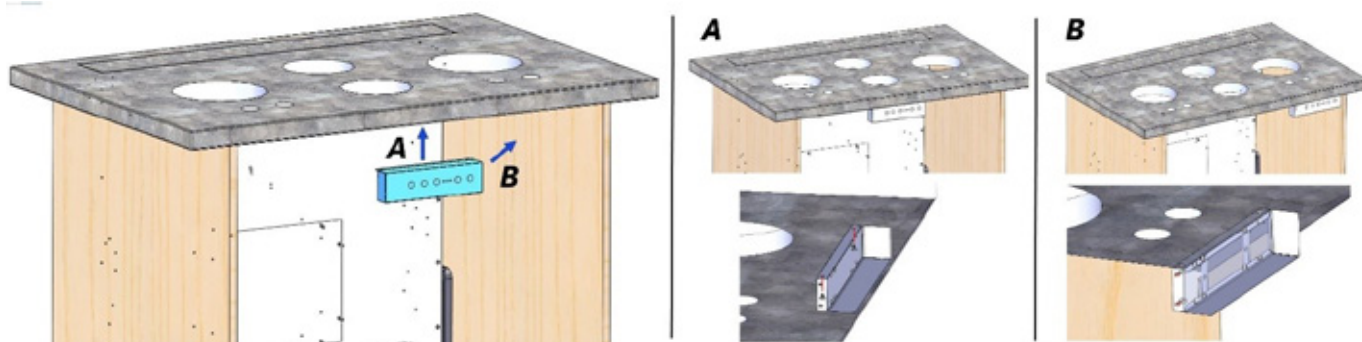

(Fig. 18)

Once the unit is fixed in position and the control buttons are fixed in place. Press the up and down arrows on the controls to raise the downdraft up from the bench. Pop the front panel forward and insert the metal grease filters. To close, push the panel forward until the magnets engage tightly.



(Fig. 19a)



(Fig. 19b)

(Fig. 20)



INSTALLATION INSTRUCTIONS SIDE OR BOTTOM VENTING

Components list at rear of Installation Guide

STEP 1A:

1. Remove front adapter plate (Part D). **(Fig. 4)**
2. Connect air outlet collar (Part 'B') to the same fixing points as removed from side or bottom cover plate (Part 'C') and tighten. Depending on sub floor clearances this step may be required prior to fixing the downdraft into place.

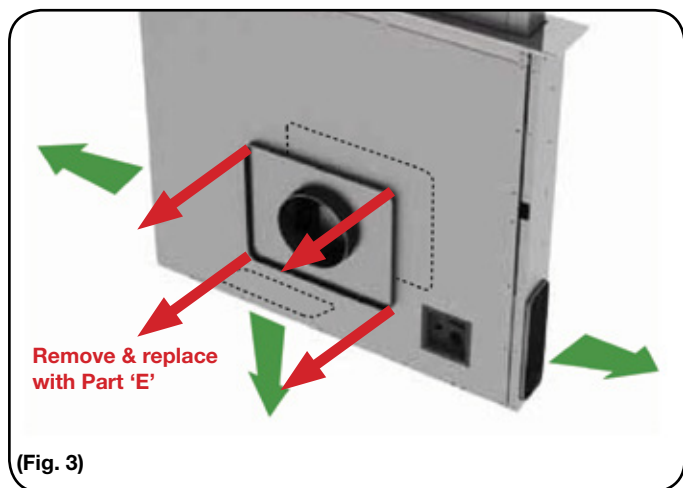

STEP 2A:

1. Remove side or bottom cover plate (Part C). **(Fig. 4)**
2. Connect air outlet collar (Part 'B') to the same fixing points as removed from side or bottom cover plate (Part 'C') and tighten.

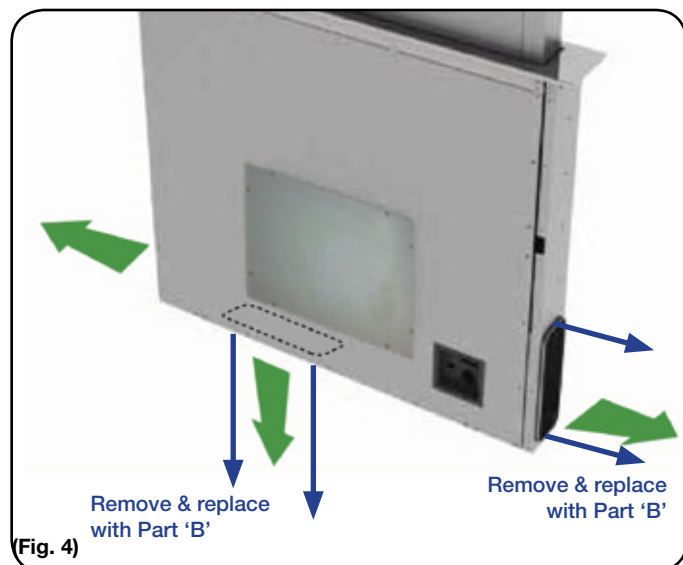

STEP 3A:

- Connect rectangular to round adaptor (Part 'A') to air outlet (Part 'B'), **(Fig. 6)**.
- Secure both ends with duct tape

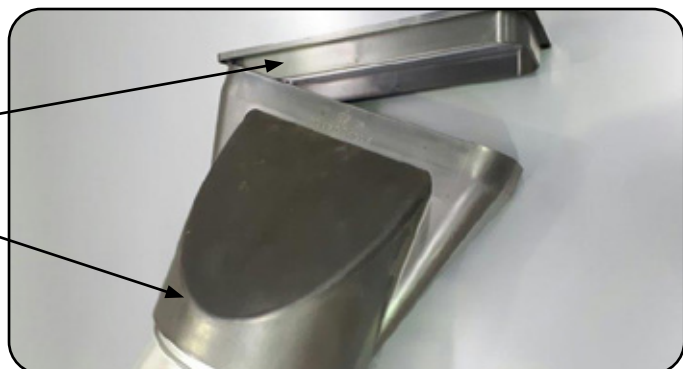

STEP 4A: Ducting to SEM 71 motor (200mm ducting)

This step covers ducting for SDD2ELEMIC 88 and 118 models.

For SEM 81 motor with SDD2ELEMIC88/118 - 200mm option only.

1B: Connect a duct expander (Part 'H') to rectangular to round adapter (Part 'A'), then connect length of ducting (Part 'K.2') to the 200mm outlet.

2B: Secure to the motor with a universal ring clamp (Part 'G').

- See page 12 for ducting to vent (N/A for SEM 71 motor)

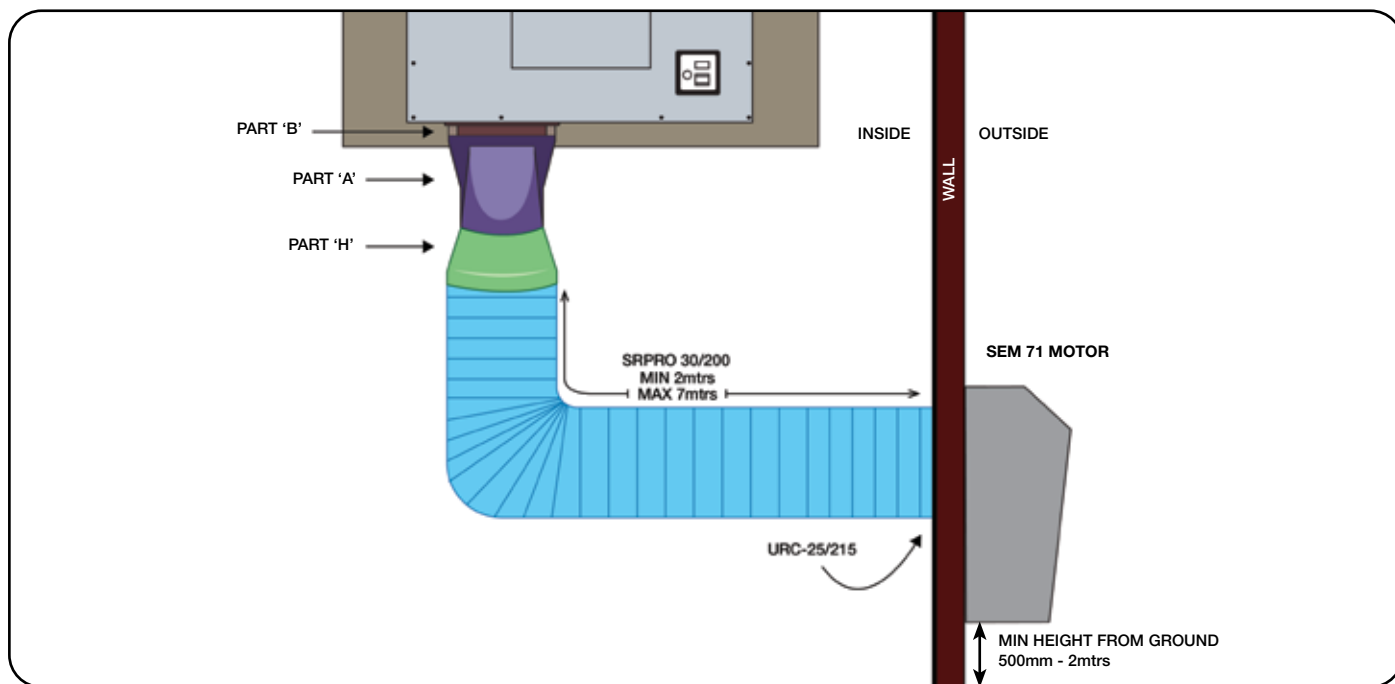

STEP 4B: Ducting to SEM 81 motor (200mm ducting)

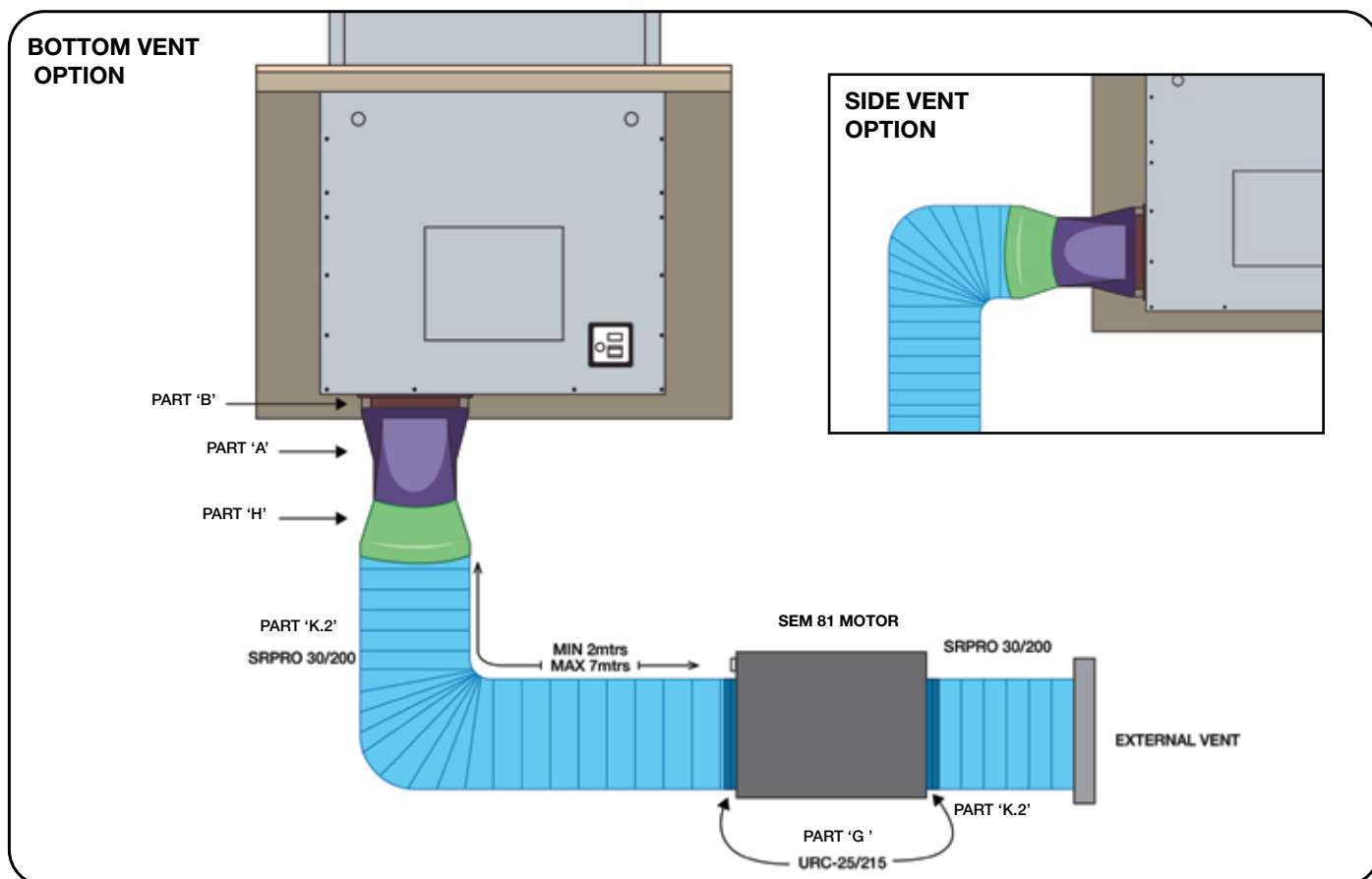

INSTALLATION INSTRUCTIONS FOR SEM 71, SEM 81 FRONT OR REAR VENTING

STEP 1B:

If venting from front, check to see if front adaptor plate (Part 'D') is attached.

- If venting from the rear, remove 200mm adaptor plate (Part 'D') and replace with front cover plate (Part 'E').

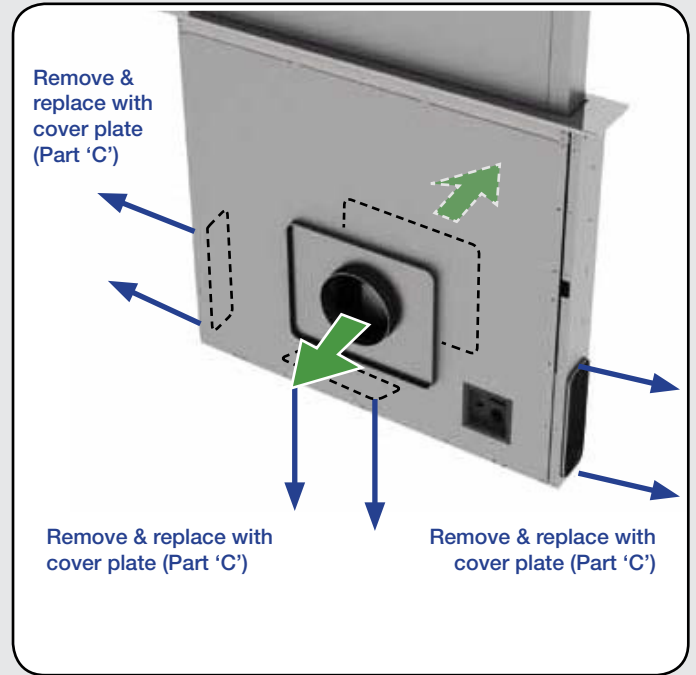

(Fig. 7)

STEP 2B:

1. Use 200mm ducting (Part 'K.2') for SDD2ELEMIC 880 and 1180 versions.
2. The ducting fits directly onto the collar on the front adaptor plate (Part 'D').
3. Fix in place using a universal ring clamp (Part 'G').

Ducting to SEM 81 motor (internal motor)

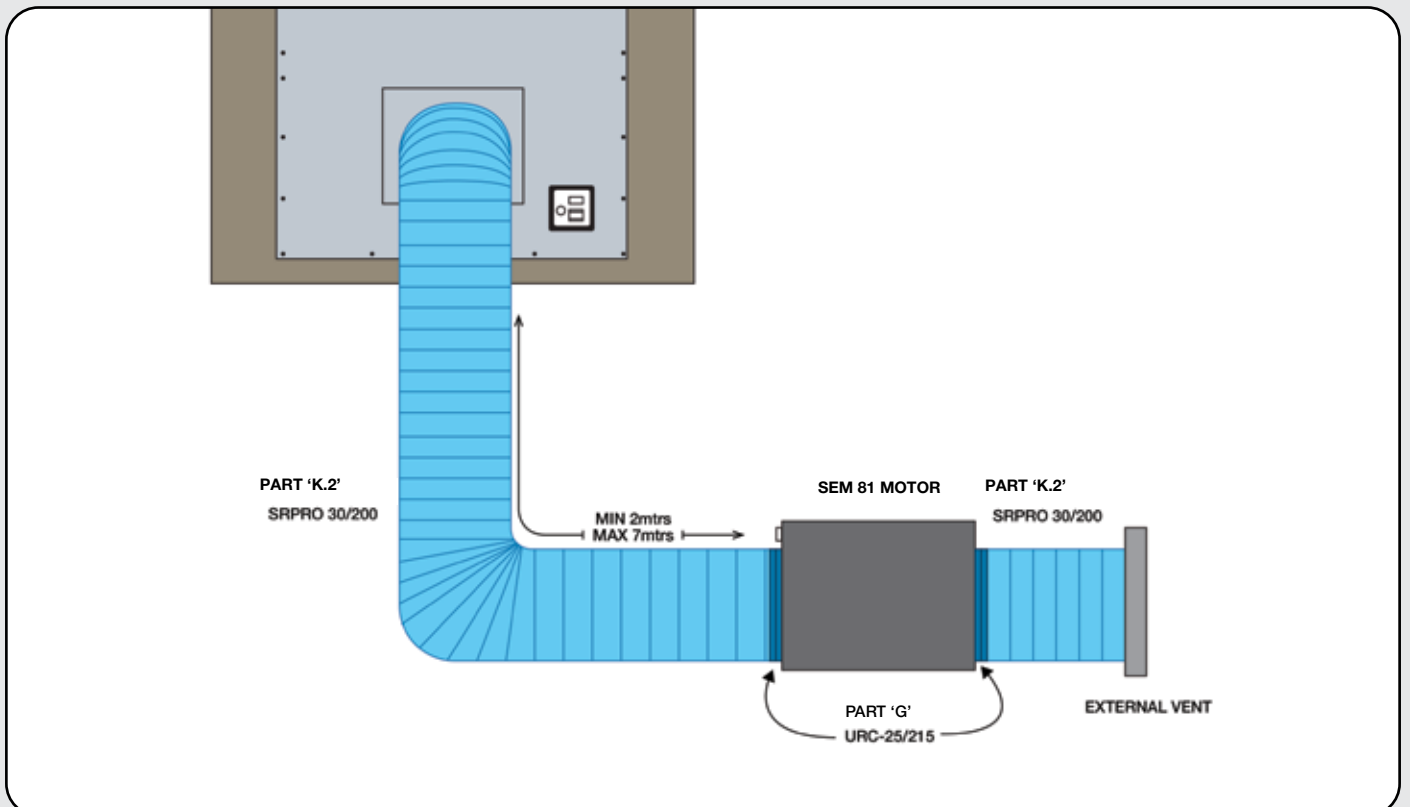

Ducting to SEM 71 motor (external motor)

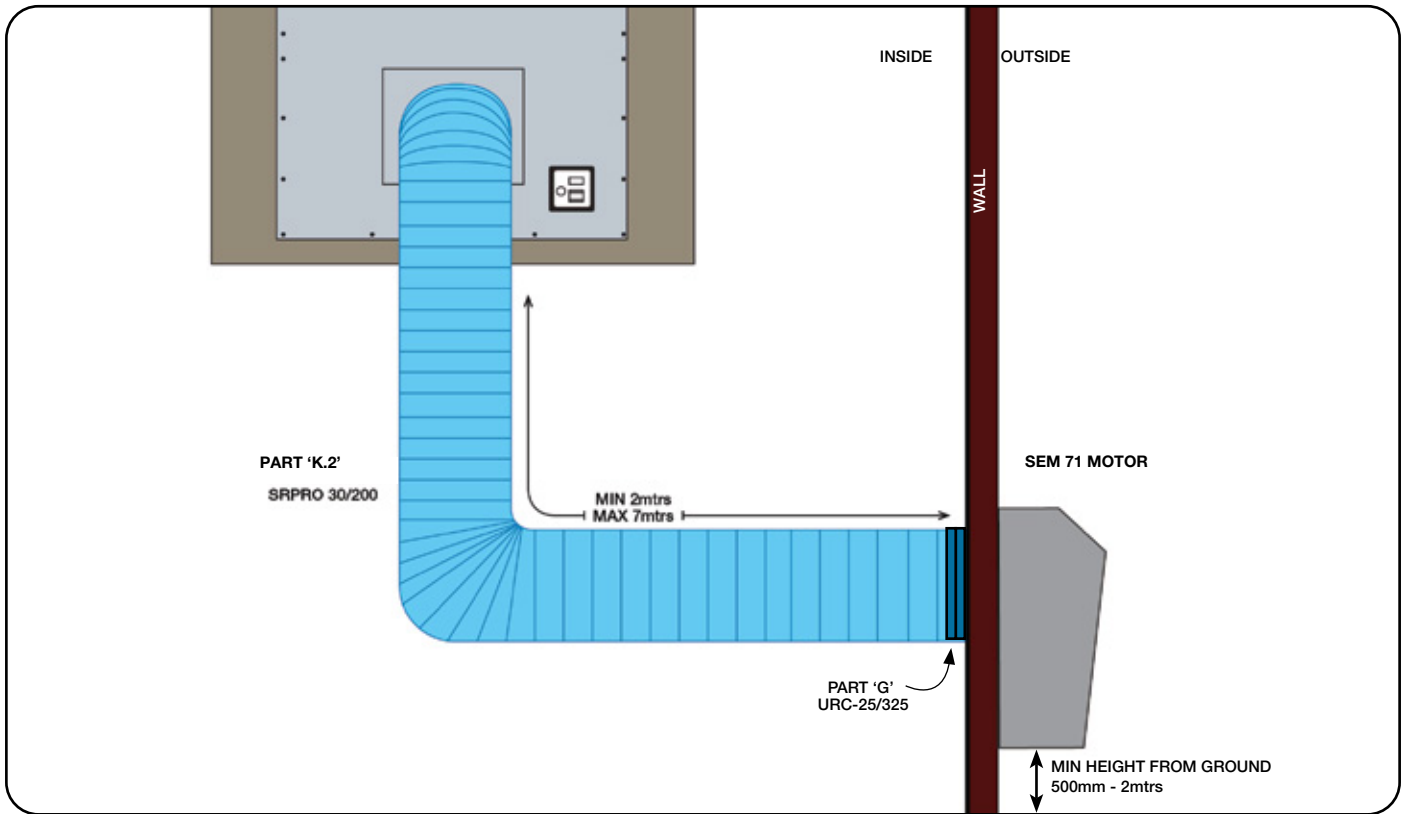

Ducting to DDFMEL motor (internal motor)

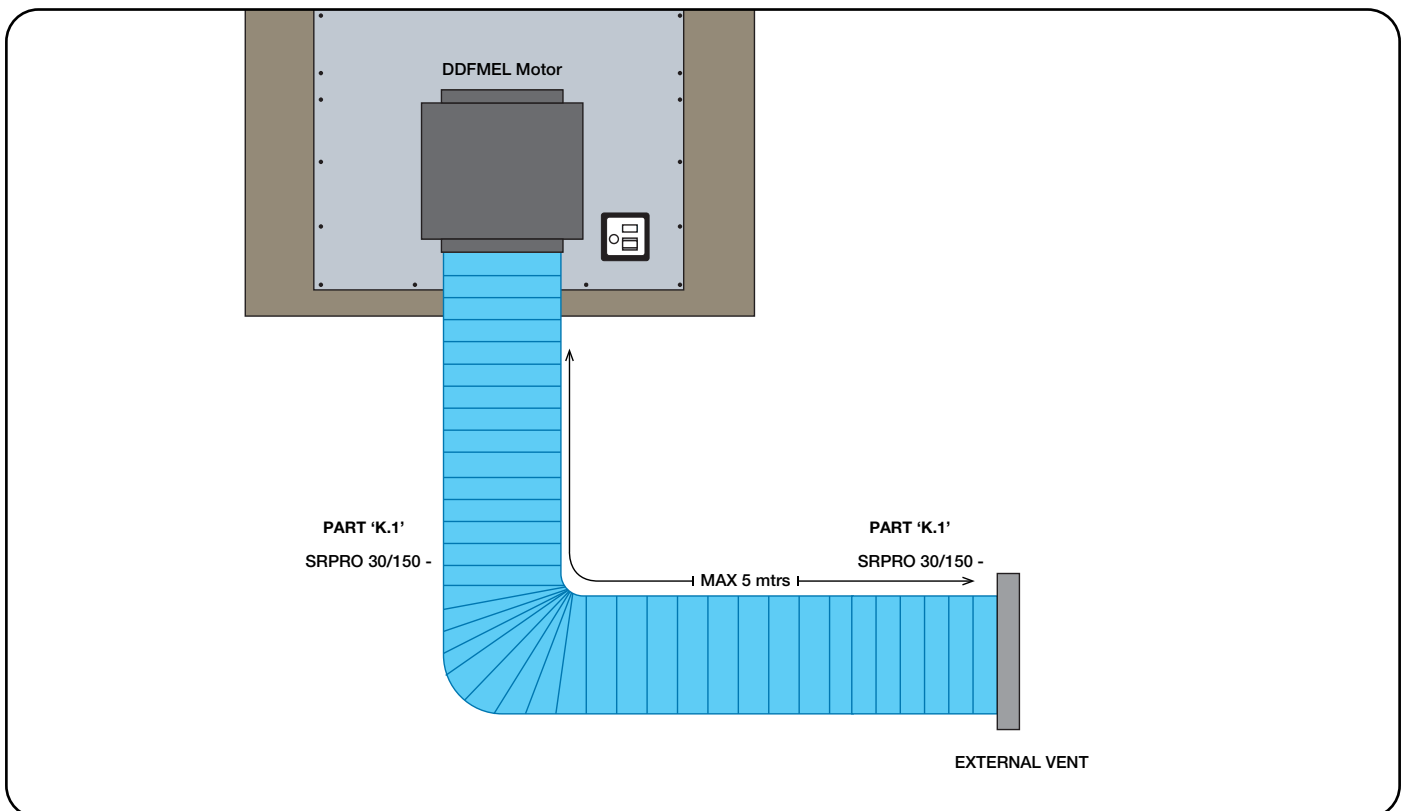

DUCTING FROM MOTOR TO WALL VENT: (SEM 81)

1. Run the length of ducting to the motor. **(Additional lengths of ducting can be attached using an additional internal connector pieces.)**

NOTE: No connector required as it connects directly to the collar of the motor.

2. Secure with another universal ring clamp (Part 'G').

NOTE: The location of the motor is to be no less than 2 metres away from the downdraft. Failure to do so may result in additional noise level of the downdraft. Maximum distance is 7 metres, however 3 - 5 metres is optimum to minimise noise and maximise performance.

3. Using another length of semi-rigid duct run from the exit collar on the SEM 81 to a predetermined exit point and connect to weatherproof vent with a clamp.

See www.siriusbrand.com for multiple vent options or see our nearest retail partner.

ELECTRICAL CONNECTION

Power transformer can be located anywhere beneath the bench. It must be accessible for servicing.

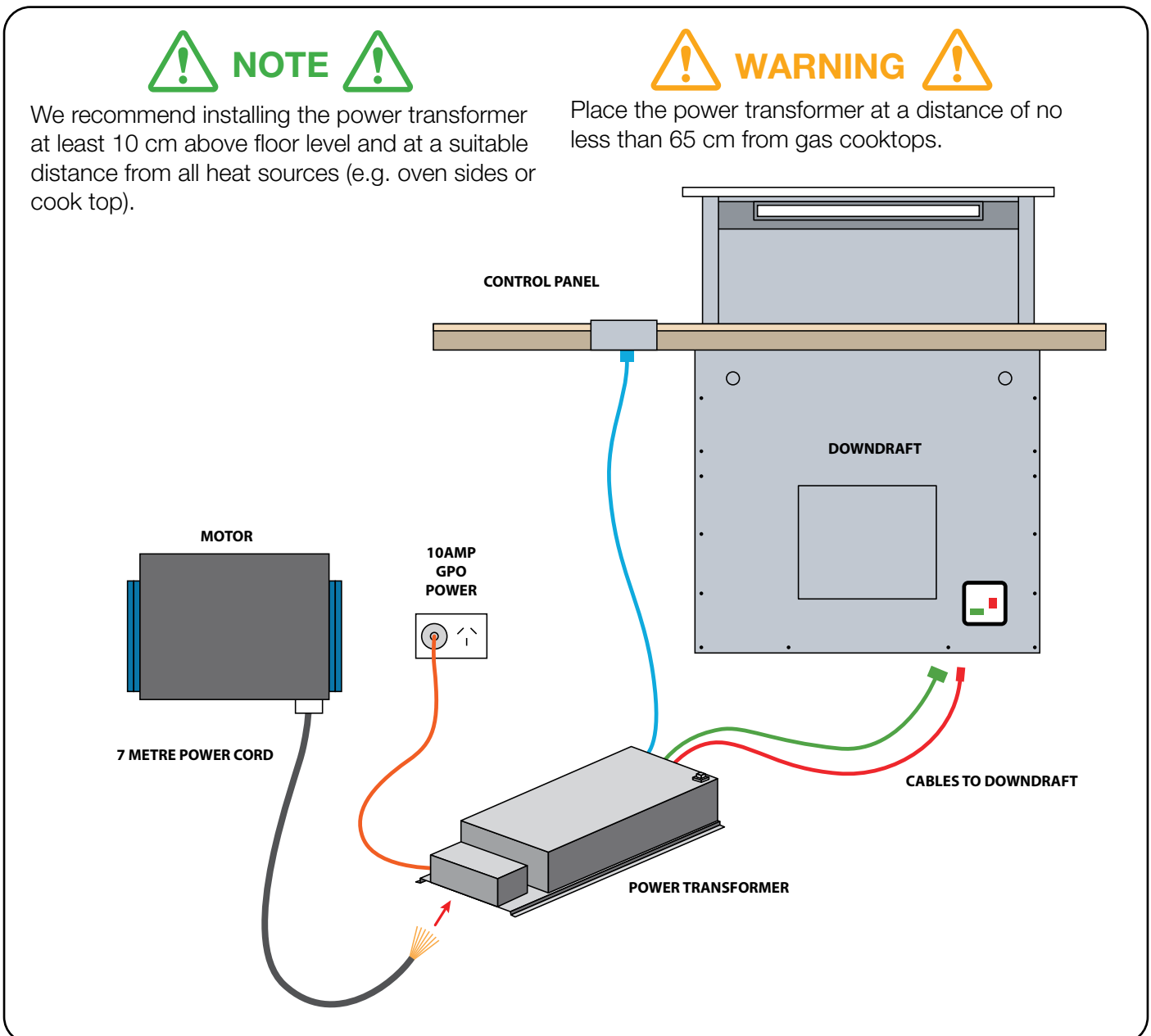

ELECTRICAL CONNECTION



This appliance complies with the European Directives 2006/95/EC (Low Voltage Directive) and 2004/108/EC (Electromagnetic Compatibility).

While installing the appliance and carrying maintenance operation, make sure it is disconnected from the electrical network or the fuses are cut out or removed.

Check that:

- Power is connected.
- Feeder lines (mains) are in good conditions.
- The cables diameter complies with installation regulations.



The downdraft connection to the electrical network must be carried out only by professional and qualified technicians.

The downdraft must be connected to a properly installed and suitable electrical network.

The electrical system must comply with VDE0100 standard.



If the rangehood presents any anomaly, disconnect the appliance or remove the fuse corresponding to the appliance power disconnecting line.

If the appliance has no plug or if the plug is not easily accessible, then a device needs to be fitted to disconnect off from the electric network; this device must have an opening distance between contacts on all poles of at least **3 mm**.



This appliance is fitted with an H05 VVF 3 conductor, 0.75 mm² (neutral, phase, and ground) power cord. This can be connected up to a 220 - 240 V monophase electrical network through a CEI 60083 approved power socket (10AMP power socket), which must remain accessible after installation, in compliance with installation regulations. We decline any responsibility in case of accidents caused by a lack of ground connection or incorrect ground connection. The appliance must be fed through a differential protection device (RCD), with a nominal residual current not exceeding 30mA. If the power cord is damaged, call the after-sales service to avoid any risk.



After having replaced the filters, reinstall the front stainless steel panel, otherwise the Downdraft is not enabled to function.



(Fig. 8)



Water splashing against the enclosure from any direction shall have no harmful effect, utilizing either: a) an oscillating fixture, or b) A spray nozzle with no shield.

Test a) is conducted for 10 minutes. Test b) is conducted (without shield) for 5 minutes minimum.

Oscillating tube: Test duration: 10 minutes, or spray nozzle (same as IPX3 spray nozzle with shield removed).

HOW THE RANGEHOOD WORKS



Light



On/Off



Decrease fan
speed



Fan speed
indicators



Increase fan
speed



10 min shut-off
timer

A: Light ON/OFF key

The light switches on and off only when the carriage is fully OPEN.

Pressing this button with the carriage closed will cause the carriage to open and then the light will switch on .

The button also serves to switch off the light if it is on.

B: ON/OFF key

This starts the extraction carriage upward movement and when it is fully open, it sets the second extraction speed.

With the carriage open: it switches off the motor and if on, the light; then it retracts the extraction carriage.

C: Decrease fan speed key

This reduces the speed of the extractor motor from the 4th speed until the motor switches off, without closing the pullout carriage.

D: Fan speed Indicators

- This signals the speed setting, by only the relevant LED switching on.
- Lights flashing signals reminder to wash mesh grease filters. (see grease filter saturation)

E: Increase fan speed key

This increases the speed of the extractor motor, from 1st to 4th speed, without moving the extractor panel.

F: 10 Minute shut-off timer

10 min after setting, it serves to stop the extractor motor, close the carriage and switch the lights off, if they are on. The set function is signalled by the flashing LEDs “D” for the set speed. The timer can be cancelled by pressing the key again.

Automatic turn off:

After 4 hours of continuous working from the last setup, the appliance turns off and closes automatically. This ensures the unit cannot accidentally be left running whilst away.

Grease filters saturation:

After 30 hours of working, the speed indicators “D” will all flash simultaneously, signaling the grease filters saturation.

To reset this alarm, hold down the “**TIMER**” button for at least 3 seconds, while the carriage is open.

Calibration:

The rangehood carries out its self-calibration every 3 complete cycles of its extractable unit.

By pushing the “**TIMER**” key 6 times consecutively (MAX break between one push and the other is 3 sec.) all the LEDs will flash and the calibration will be reset.

After the next 3 cycles the downdraft will carry out its self-calibration.

Stand-by:

When the extractable unit is closed and the light is switched off, the control panel, after 6 seconds, activates the Stand-by function, reducing the brightness of the leds.

This function can be stopped by pressing **ON/OFF** or **LIGHT** key.

Safety close function:

If an obstacle is preventing the downdraft from lowering completely, the downdraft will automatically raise to prevent damage to the unit.

IF THE PRODUCT WORKS WITH SUPPLIED REMOTE CONTROL

Remote control (Fig.11).

channel radio control for cooker hood remote.

At first ignition, keep pressed the lighting button for 5 seconds.

RC001

RADIO CONTROL

Radio control used for the remote operation of ducted cooker hoods.

TECHNICAL DATA

- Alkaline battery powered: 12 V mod. 27A
- Operating frequency: 433.92 Mhz
- Combinations: 32.768
- Max. consumption: 25 mA
- Operating temperature: -20 ÷ + 55 °C
- Dimensions: 130x45x15 mm.

OPERATING DESCRIPTION

The transmitter is equipped with 5 buttons for cooker hood management, as specified below:

 : Light ON/OFF command.

 : Motor ON (speed level 1) / OFF command.

 : Reduce speed.

 : Increase speed.

 : 10-minute timer.

INITIAL OPERATING CONDITION

The manufacturer supplies the radio control unit ready to be used with codes preset in the Factory



OPERATION MODE

Standard configuration:

Standard configuration requires all “cooker hoods – radio control - system” to be provided with the same transmission code. In the event two cooker hoods – radio control system are installed in the same room or nearby, each system may affect the operation of the another. Therefore, the code of one radio control system must be changed.

Generating a new transmission code:

The radio control system is provided with preset codes. Should new codes be required, proceed as follows: Press simultaneously buttons:



for two seconds. When Leds light on, press buttons:

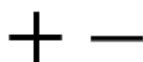

(within 5 seconds). Leds flashing 3 times indicate the procedure is completed.

WARNING! This operation deletes permanently the preset codes.

Learning the new transmission code:

Once the transmission code is changed in the radio control unit, the electronic central unit of the cooker hood must be made to set the new code in the following way:

Press the main power-off button of the hood and then restore power to the electronic control unit. Within the next 15 seconds, press the Light Button  to synchronise the central unit with the code.

Reset of the Factory configuration:

To restore the Factory configuration, follow the procedure described below: press simultaneously buttons:



for 2 seconds. When Leds light on, press buttons:

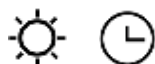

(within 5 seconds). Leds flashing 6 times indicate the procedure is completed.

WARNING! This operation deletes permanently the preset codes.

Emergency button:

In the event that the radio control does not work, use the emergency button to switch the appliance off. After any necessary repairs have been performed, reset the emergency button.

WARNING

The battery should be replaced every year to guarantee the optimal range of the transmitter.

To replace the exhausted battery, take the plastic lid off, remove the battery and replace it with a new one, observing the correct battery polarities.

Used batteries should be discarded in special collection bins.

The below product:

RC001 Radio Control

complies with the specifications set out in the Directive RED 2014/53/EU.



WARNING

Any adjustments or modifications which have not been expressly approved by the holder of the legal conformity certificate may invalidate the user's rights relating to the operation of the device.

Rev. 0 26/08/14

The products are endowed with an electronic device which allows the automatic switching off after 4 hours working from the last operation.

Other functions:

Automatic turn off:

After 4 hours of continuous working from the last setup, the appliance turns off and closes automatically.

Grease filters saturation:

After 30 hours of working, the speed indicators "D" will all flash simultaneously, signaling the grease filters saturation. To reset this alarm, hold down the "TIMER" button for at least 3 seconds, while the carriage is open.

Calibration:

The cooker-hood carries out its self-calibration every 3 complete cycles of its extractable unit. By pushing the "TIMER" key 6 times consecutively (MAX break between one push and the other is 3 sec.) all the leds will flash and the calibration will be reset.

After the next 3 cycles the downdraft will carry out its self-calibration.

Stand-by:

When the extractable unit is closed and the light is switched off, the control panel, after 6 seconds, activates the Stand-by function, reducing the brightness of the leds.

This function can be stopped by pressing ON/OFF or LIGHT key.

Security system:

If there is an obstacle while the extractable unit is closing, the Downdraft stops closing and rises again thanks to a security system.

WARNING

This operation has to be carried out by a specialized technician.

CLEANING THE RANGEHOOD

Careful maintenance ensures proper operation and good performances over time.



The hood must be disconnected from the electrical network, both by unplugging the appliance from the socket and activating the magnetic circuit breaker (safety cut-out), before removing the metal grease filters. After cleaning operations, replace the metal grease filters as outlined in the installation instructions.

MAINTENANCE	HOW TO PROCEED?	ACCESSORY PRODUCTS TO USE
External surfaces and accessories	Do not use metallic scrubbers, abrasive products, or hard brushes.	To clean the external surfaces of the rangehood and the light housing screen use only commercially available household detergents diluted in water. Then rinse with clean water and dry with a soft cloth.
Filter cleaning	After 30 hours of operation, the downdraft will signal the grease filter saturation. The saturation is signaled by the blinking of the 4 central leds. To reset, hold down the timer button  for at least 3 seconds, while the carriage is open.	The grease filters can be washed by hand or in the dishwasher. These filters need to be cleaned on a regular basis, otherwise they may represent a fire risk. If frying or cooking with oil, the filters need to be cleaned more regularly. Refit the grease filters and front panel, making sure that the panel is properly fitted at the sides so that it does not cause the downdraft to stop operating.
NB: Filters should be replaced approximately every 6 months, depending on style and frequency of cooking. For high fat cooking it is recommended to clean the filters every 2 weeks.		

TROUBLESHOOTING

PROBLEM	SOLUTION
The rangehood does not work.	Check that: <ul style="list-style-type: none">• There is not a power outage.• A specific speed has actually been selected.• The 6 pin connection is inserted properly.• The red reset key, found over the electrical system box, is pushed.• Make sure that the wires of the 9 pole connection are inserted properly in the connector itself (during the connection phase, an excessive pressure could bend the contacts).
The rangehood has low performance.	Check that: <ul style="list-style-type: none">• The motor speed selected is sufficient for the quantity of fumes and vapors present in the room.• The kitchen is ventilated well enough to allow air for intake.• The non-return valves of the suctioning unit are free to rotate.• The ducting is clear and not obstructed.• Unit is only working on 2 speeds - refer to page 5.• The correct minimum diameter ducting has been used
The rangehood stops in the middle of operation.	Check that: <ul style="list-style-type: none">• There is not a power outage.• The safety switch has not tripped (RCD or safety switch).

REPLACING THE LIGHT

1. Lift the unit, then press the red button on the power transformer - cutting power to the unit.

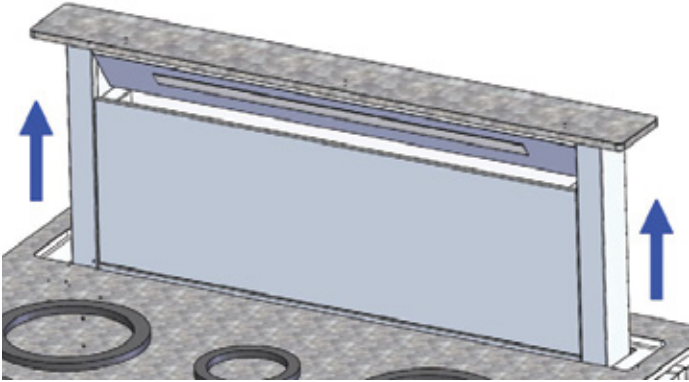

2. Using an appropriate tool, remove the LED bar from its seat, disconnect it electronically through the appropriate connector then replace it with a LED bar with same characteristics.

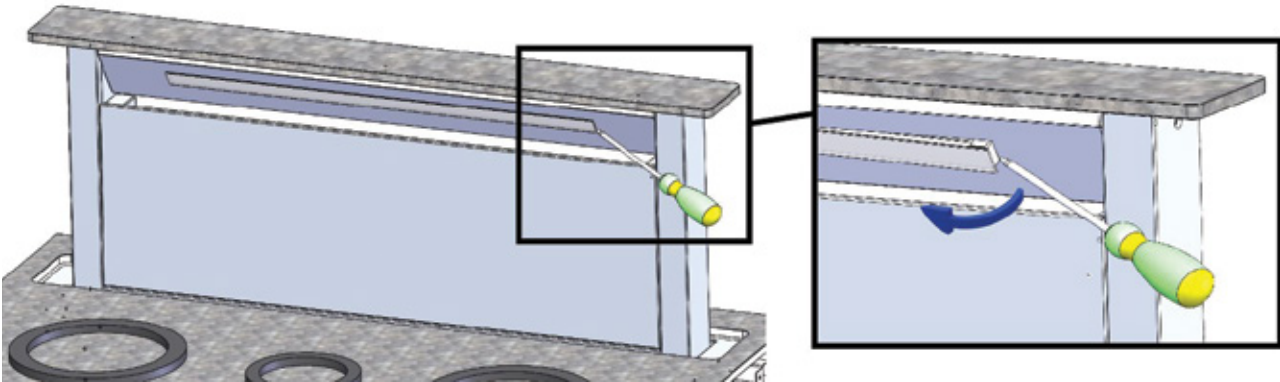

AFTER SALES SERVICE

Any maintenance operation on your appliance should be carried out by:

- Either Arisit Pty Ltd;
- Or a qualified professional technician, authorized for that brand if out of warranty.

Contact www.siriusbrand.com
1300 762 219



NOTE

When calling, please mention the appliance details: Production date, (Fig. 9A), Type (Fig. 9B) and equipment (Fig. 9C).

This information is mentioned on the rating label and the production date one placed on the lower side of the downdraft.

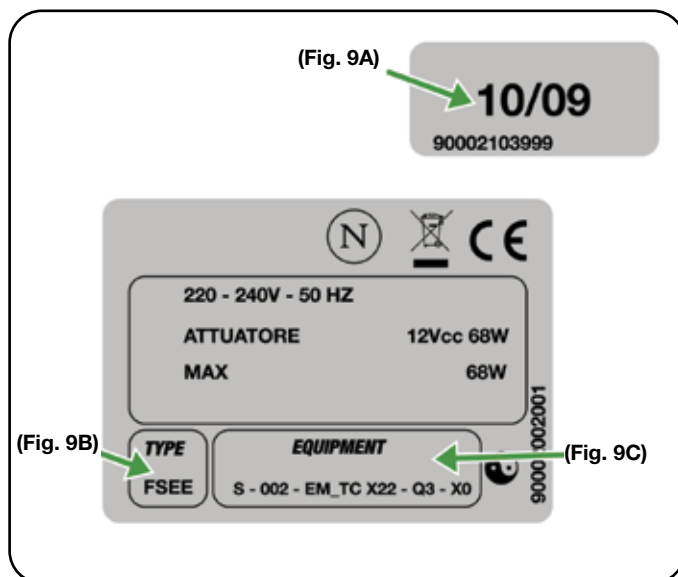

(Fig. 9)

PARTS LIST

A	RECTANGULAR TO ROUND DUCTING ADAPTOR	SPS-75000081020
B	BOTTOM/SIDE COVER COLLAR	SPS-75070102735
C	BOTTOM/SIDE EXIT PLATE	SPS-75070100094
D	FRONT/REAR VENT ADAPTOR - 58 MODEL	SPS-75070100311
D	FRONT/REAR VENT ADAPTOR - 88/118 MODEL	SPS-75070100071
E	FRONT/REAR VENT COVER PLATE	SPS-75059000082
F	UPRIGHT FIXING BRACKETS	SPS-75070100112
G	UNIVERSAL RING CLAMP	URC25-215
H	150MM TO 200MM DUCT EXPANDER	GDR 150/200
I	150MM DIAMETER CONNECTOR PIECE	GDC-150
J	200MM DIAMETER CONNECTOR PIECE	GDC-200
K	K.1 - DUCTING 150MM K.2 - DUCTING 200MM	SRPRO 30/150 SRPRO 30/200

PARTS LIST - INCLUDED PIECES

PART A

Rectangular to round ducting adaptor
SPS-75000081020



PART B

Bottom/side cover collar
SPS-75070102735



PART C

Bottom/side exit connector
SPS-75070100094

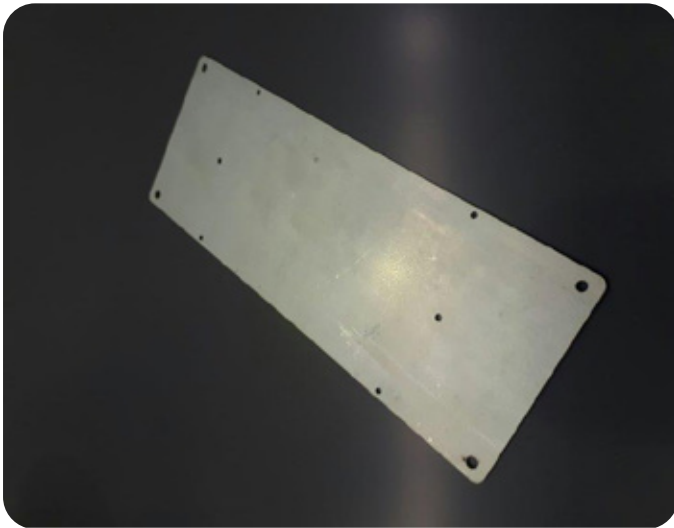

PART D

Front/rear vent adaptor
SPS-75070100311 (For 58 Model)
SPS-75070100071 (For 88/118 Model)

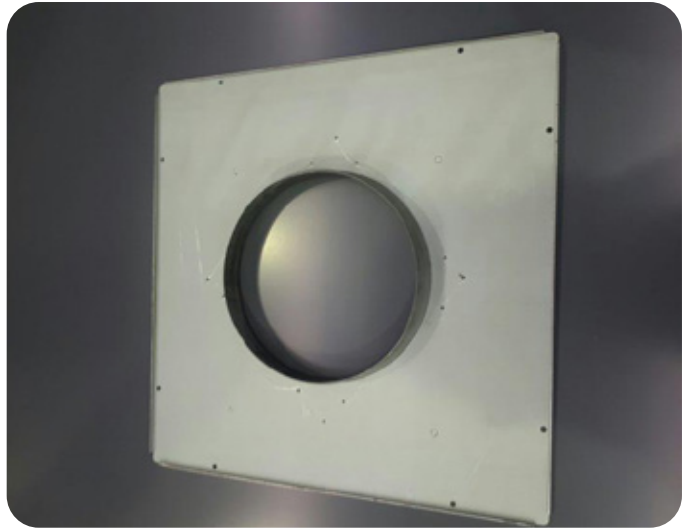

PART E

Front/rear vent cover plate
SPS-75059000082



PART F

Upright fixing brackets
SPS-75070100112



PARTS LIST - OPTIONAL PIECES

To be purchased separately

PART G

Universal ring clamp
URC25-215/325



PART H

150mm to 200mm Duct expander
GDR 150/200



PART I

150mm diameter connector piece
GDC-150



PART J

200mm diameter connector piece
GDC-200



Part K.1 / K.2

Semi rigid aluminium ducting 150mm / 200mm
SRPRO 30/150 or SRPRO 30/200

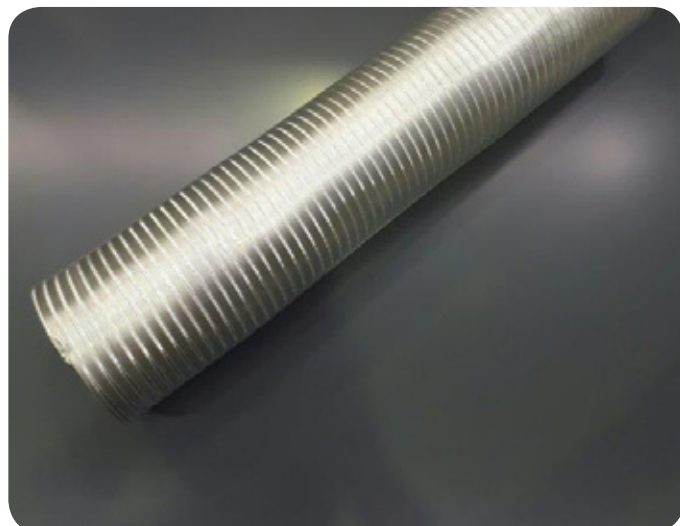

WIRING DIAGRAMS

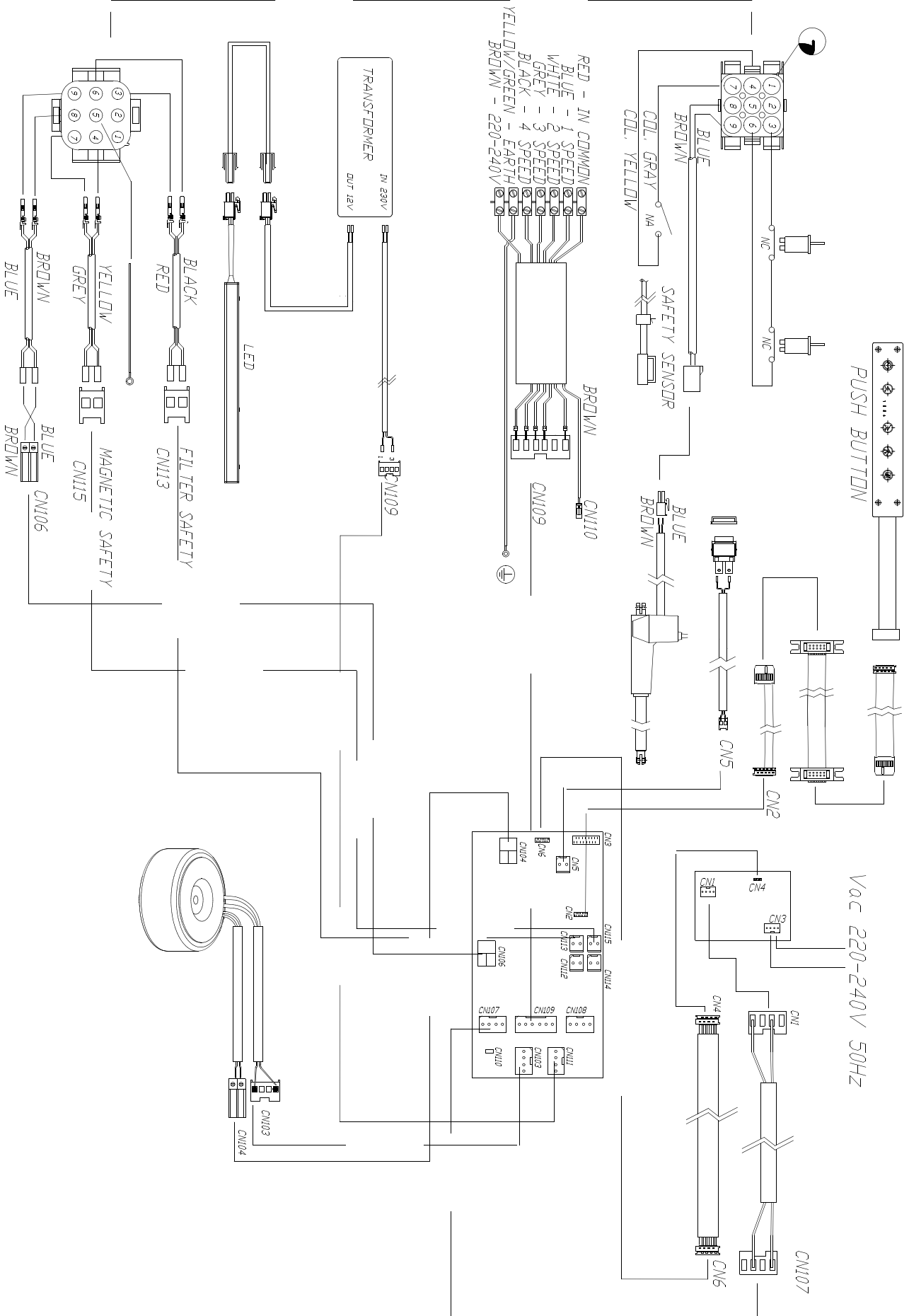

WARRANTY INFORMATION



Sirius

Dear Customer,

Thank you for choosing this Sirius Rangehood.

We are sure that it will provide you with many years of excellent service. At Arisit Pty Limited we are dedicated to ensuring that our customers receive the best possible after-sales care.

The Sirius 'Protection Plan' has been devised to give you added peace of mind. Should you encounter any problems with your appliance, our nationwide team of specially trained technicians will deal with your call swiftly and efficiently.

PRIORITY SERVICE, ACCESSORIES & SPARE PARTS

AUSTRALIA

ARISIT PTY LIMITED
40-50 Mark Anthony Drive, Dandenong South,
VIC 3175, Australia
Phone: 1300 762 219
Email: consumer.care@arisit.com

NEW ZEALAND

ARISIT PTY LIMITED
1A Howe Street, Newton,
Auckland 1145, New Zealand
Phone: (09) 306 1020
Email: sales@aristonappliances.co.nz

Warranty

By registering your ownership NOW, you qualify for Sirius's Total Peace of Mind Protection Plan.

Australian & New Zealand 3 / 6 Year Protection Plan*

This guarantees your appliance for a full 3 years parts and labour & 10 years for the off-board motors (covering manufacturing defects only) from the date of purchase, subject to the Terms and Conditions overleaf.

***3 Year warranty is extended to a 6 year period only when Sirius ducting is installed.**

 **Year Warranty**
when Sirius ducting is used*
www.siriusbrand.com

Your Warranty

Register now to qualify.

Terms & Conditions

These Terms and Conditions apply only to Sirius products distributed in Australia and New Zealand by Arisit Pty Limited.

1. This warranty applies for a period of 3 years on all products.
 - a) Warranty is extended to a 6 year period when Sirius ducting is installed.
 - b) All off-board motors are covered under warranty for a 10 year period for manufacturing defects only.
2. Warranty applies for parts and labour in Australia and New Zealand, commencing from date of purchase.
3. This warranty applies only to the original purchaser/hire purchaser of this appliance and cannot be assigned or transferred. Failure to produce documentary proof of the date of original acquisition by the original purchaser will result in a charge being levied for work done, labour and parts supplied.
4. This warranty does not apply to:
 - a) Consumable items such as filters, fuses, and light bulbs.
 - b) Damage to body work, paint work, glass, and plastic items (such as, but not limited to windows, covers, baskets, trays, worktops, door handles, control and kick panels.)
 - c) Corrosion & rust damage.

A fee may be charged following warranty claims where no fault is found with the appliance.

5. This warranty will not apply where:
 - a) The fault is caused by accident, misuse, an infestation of insect and or vermin, fire, flood or the use of products not approved by Arisit Pty Limited.
 - b) There has been a failure to comply with the manufacturer's operating and installation instructions.
 - c) Service, modification or repair has been carried out by anybody other than an approved Arisit Service Technician.
 - d) The appliance has been used/ installed anywhere other than a private dwelling, or where it has been used other than for domestic use.
 - e) The appliance is subject to a rental agreement.
6. Any defective part that has been replaced becomes the property of Arisit Pty Limited.
7. This warranty applies only to Sirius appliances purchased and installed in Australia and New Zealand.
8. Loss of use of the appliance or consequential loss of any nature is not covered.
9. A charge may be levied at the discretion of Arisit Pty Limited if the call is deemed unnecessary or if the cause of failure is traced to external sourced such as, but not limited to: blown fuses, power failure, faulty installation, customer misuse or negligence, etc
10. Where the appliance, the subject of a warranty claim or repair, is used or installed more than TWENTY (20) kilometres from the nearest Arisit Service Division or Authorised Service Agent, the

cost of delivery to the nearest Service Division or travel costs for a technician or Authorised Service Agent shall be for the account of the Purchaser. Where a built-in appliance is located or installed outside the Arisit Authorised Service Agent's normal service area, additional travel and labour costs shall be the account of the Purchaser.

11. Service is offered during normal business hours only, also appliances to have a clear access in a serviceable area
 12. Arisit Pty Limited shall not under any circumstances be responsible in terms of this warranty for the replacement or repair of any part of the equipment which may have been damaged in transit, during and after installation or imperfections after installation.
 13. Losses caused by act of God, failure to obtain spare parts, strikes or lockouts are not covered.
 14. External off board motors must be installed a minimum of 2 metres and maximum of 7 metres away from the rangehood. This is for optimum sound and performance.
 15. All motors must be accessible for servicing purposes and if installed above 2 metres from ground height additional cost will be incurred due to OH&S standards for service agents. Prior to install please check minimum & maximum installation details on the Sirius website, FAQ under support tab.
- We reserve the right to amend any of the above without prior notice.
16. This warranty does not affect your statutory rights.

To register for your warranty, please visit:

www.arisitwarranties.com.au/Customer-Registration.aspx

or scan the QR code.



ARISIT PTY LIMITED (Australia)

AEBN 23 091 515 294

40-50 Mark Anthony Drive
Dandenong South VIC 3175

P: Sales & Service: 1300 762 219

F: Sales & Service: (03) 9768 0838

E: arisit@arisit.com

ARISIT PTY LIMITED (New Zealand)

1A Howe Street Newton, Auckland 1145
PO Box 68-140 Newton, Auckland 1145

P: (09) 306 1020 - Fax: (09) 302 0077

E: sales2@aristonappliances.co.nz

www.arisit.com

www.siriusbrand.com

**6 Year
Warranty**

when Sirius ducting is used.

Full replacement warranty on parts and labour. Check website for T&Cs.

10 year warranty on SEM motors.

Sirius Hoods and ducting products are only available from our select group of Sirius Professional Stockists nationwide. For the latest list of Sirius Stockists near you, please refer to www.siriusbrand.com

All efforts have been made to ensure that the information provided in this brochure is correct at the time of printing. Due to continuous product improvement and ongoing development, Sirius reserves the right to make changes to the products and technical data without prior notice. Some products appearing in this brochure may be for illustrative purposes only. Diagrams are indicative measures only. Prior to commencing cabinetry cutouts the operating/installation instructions accompanying the product must be referred to at www.siriusbrand.com