

# 1500mm ONBOARD UNDERMOUNT RANGEHOOD - TRIPLE MOTOR

SL906DLTM150

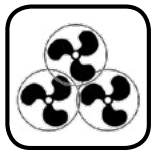

Rangehood type	Undermount
Control	Button
Speed settings	4
Ducting diameter	300mm
Extraction type	Onboard motor
Green Energy Motor	Triple aluminium motor
Extraction	2600m <sup>3</sup> /h
Filter	25mm stainless steel baffle
Dynamic Lighting	Adjustable and dimmable lighting
Induction Countdown Control	Yes
Electrical requirement	10A
Noise	64dB
Dimensions (mm)	W1500 x D380 x H322
Weight	45kg
Cut-out dimensions (mm)	W1480 x D364
Warranty	3 years (6 years when Sirius ducting is used)



**GREEN ENERGY  
TRIPLE MOTOR**



**25mm BAFFLE  
FILTERS**



**2600m<sup>3</sup>/h  
AIRFLOW**

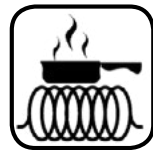

**INDUCTION  
SAFE**



**DYNAMIC  
LIGHTING**



**HANDCRAFTED  
IN ITALY**

## Ducting options

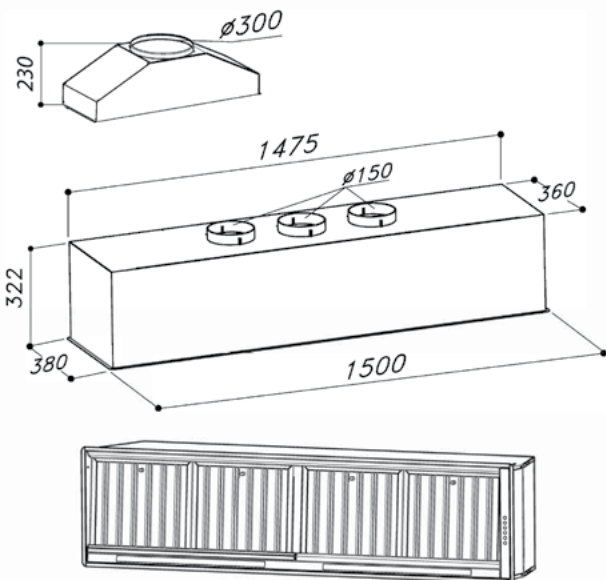

\*Product dimension includes trim

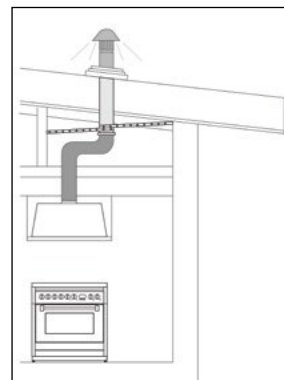

Roof ducted

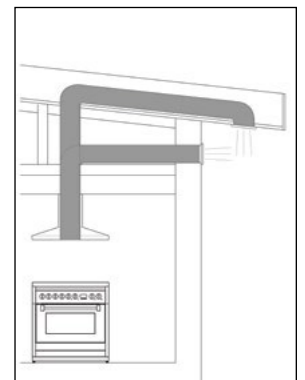

Eave or Wall ducted

- Use semi-rigid or rigid ducting, not fully flexible foil ducting.
- Fewer bends means a quieter and more powerful extraction.
- Bonus 3 years warranty when Sirius ducting is used (total 6 years).
- See [support page](#) on Sirius website for installation videos and FAQs.

WARNING: technical specifications and product sizes can be varied by the manufacturer, without notice. Cut outs for appliances should only be by physical product measurements. The above information is indicative only.

Distributed by Arisit Pty Ltd

40-50 Mark Anthony Drive, Dandenong South VIC 3175

Ph: 1300 762 219

Fax: 03 9768 0838

Website: [www.arisit.com](http://www.arisit.com)

[www.siriusbrand.com](http://www.siriusbrand.com)