

900mm OFFBOARD CANOPY RANGEHOOD - MATTE BLACK FINISH

SLTCEM97900



Rangehood type	Canopy
Control	Touch control
Speed settings	4
Ducting diameter	150mm
Extraction type	Offboard motor
Motor*	SEM1/SEM11, SEM2XS316/ SEM21, SEM5XS316 / SEM51
Extraction	1200m ³ /h
Filter	10mm stainless steel baffle
Lighting	2 x 6W LED strips
Induction Countdown Control	Yes
Electrical requirement	10A
Dimensions (mm)	W900 x D550 x H690-1200
Weight	26.5kg
Warranty	3 years (6 years when Sirius ducting is used)



**INDUCTION
SAFE**



**10mm BAFFLE
FILTERS**

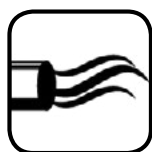

**1200m³/h
AIRFLOW**



**EUROPEAN-
MADE MOTOR**



**2 x 6W LED
LIGHTING**



**HANDCRAFTED
IN ITALY**

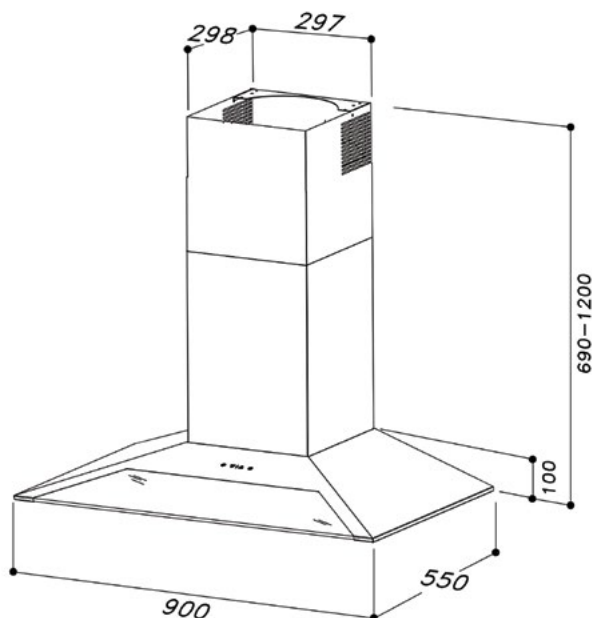

*Outdoor offboard motors have a marine grade finish as standard for added resistance to coastal weather elements.

Ducting options

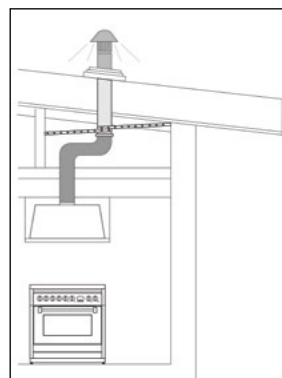

Roof ducted

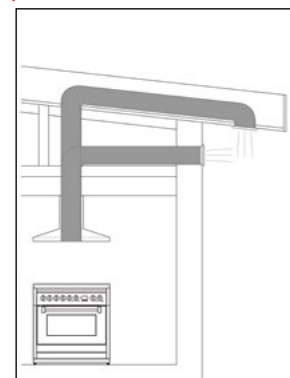

Eave or Wall ducted

- Can be used with SEM1/SEM11, SEM2/SEM21, and SEM5/SEM51.
- Use semi-rigid or rigid ducting, not fully flexible foil ducting.
- Fewer bends means a quieter and more powerful extraction.
- Extra 3 years warranty when Sirius ducting is used (total 6 years).
- See [support page](#) on Sirius website for installation videos and FAQs.

WARNING: technical specifications and product sizes can be varied by the manufacturer, without notice. Cut outs for appliances should only be by physical product measurements. The above information is indicative only.

Distributed by Arisit Pty Ltd

40-50 Mark Anthony Drive, Dandenong South VIC 3175

Ph: 1300 762 219

Fax: 03 9768 0838

Website: www.arisit.com

www.siriusbrand.com