

S-DDH1.1

4 Zone Induction Cooktop with Integrated Down Draft



Features and Benefits:

Warranty	3 Year Warranty (4 year warranty when Sirius ducting used)
Booster Function on all Zones	Booster function to temporarily supply additional power to an induction zone to bring food to high temperatures quickly.
Bridge Function	Allows you to combine two cooking zones into 1 larger zone with combined power for larger pots. Four zone model offers one bridge between the left hand zones and one between the right hand zones.
Automatic Heat Up Function	Allows your cooktop to reach its desired heat at a faster rate by operating a full capacity and automatically switching back when the selected heat level is reached.
Keep Warm Function	Keeps your dishes warm to maintain food temperature before serving.
Touch Control	Electronic controls with sensitive touch keys for both the rangehood and induction cooktop allowing you to accurately and easily control temperatures and extraction specifications.
4 Speed Extraction	4 speed extraction provided in rangehood to allow you to control air extraction levels.
Safety Features	A variety of safety functions to provide an extremely safe cooktop design. Safety lock to prevent children from accidentally switching the cooktop on as well as timer function, over heating protection and operating time limitation.
Easy Clean Induction Surface	Smooth and easy to clean cooktop surface with no areas to attract grime and grease.
LED Lighting	10 watt LED strip light within rangehood design to provide efficient lighting during your cooking.
Stainless Steel Body	Rangehood made of AISI 304 grade stainless steel to provide a sturdy and durable finish.
MADE IN ITALY	Units are designed specifically for the Australian market and manufactured in Italy by dedicated boutique specialist manufacturer.

Distributed by Arisit Pty Ltd

40-44 Mark Anthony Drive, Dandenong South VIC 3175 Phone: 1300 762 219 Fax: 03 9706 6904 Website: www.arisit.com

www.siriusbrand.com

S-DDH1.1

4 Zone Induction Cooktop with Integrated Down Draft

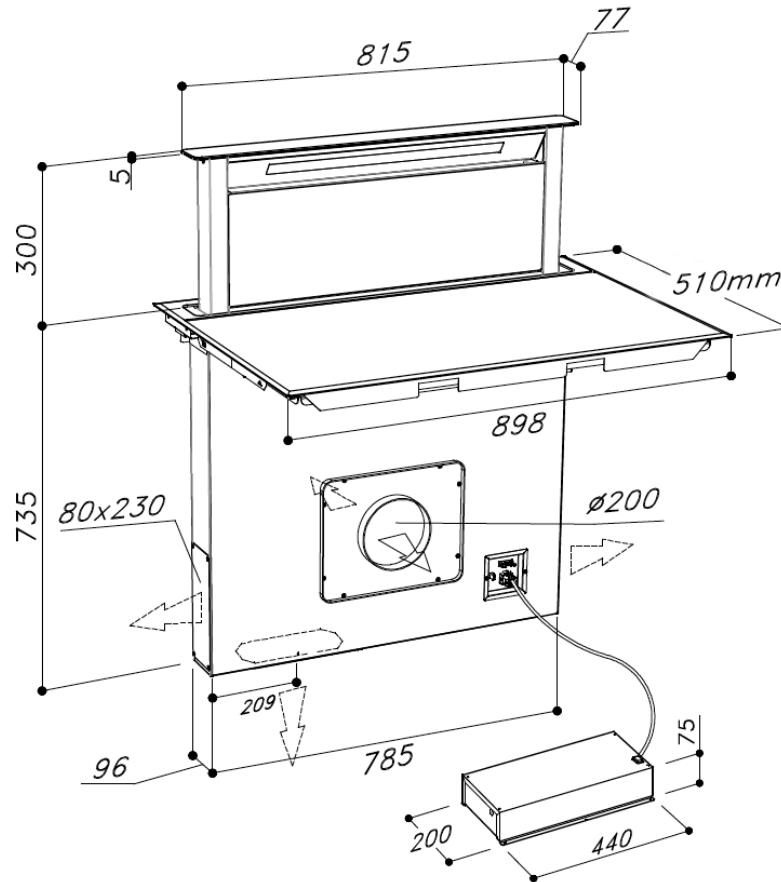

Model	S-DDH1.1
Control Panel	Touch Control
Cooker Configuration	4 x Zone Induction (3 x 2.1KW & 3.7KW with Booster) with 2 x Zone Bridges
Total Amps	32 AMPS
Electric Rating	220-240V (50-60Hz)
Extraction Motor	SEM 7 or SEM 8
Filter	Anodized Aluminium (4+1)
Induction Surface	(W) 898mm x (D) 510mm
Product Dimensions	(W) 898mm x (D) 510mm x (H) 735mm (1035mm Height at Full Extension)
Cut Out Product Dimensions	(W) 860mm x (D) 490mm + 50mm Rear Clearance

WARNING: Technical specifications and product sizes can be varied by the manufacturer, without notice. Cut outs for appliances should only be physical product measurements. The above information is indicative only.

Distributed by Arisit Pty Ltd

40-44 Mark Anthony Drive, Dandenong South VIC 3175 Phone: 1300 762 219 Fax: 03 9706 6904 Website: www.arisit.com

www.siriusbrand.com