

# SDD2 EMTC 580 WH

58CM DOWNDRAFT HOOD WITH WHITE GLASS PANEL



let's get  
**Sirius**  
with rangehood design



## SDD2 EMTC 580 WH

### Features and Benefits:

DOWNDRAFT DESIGN	Perfect for island installation offering an alternative to bulky island hoods, Modern aesthetic, retractable for unrestricted vision, installed in bench making it versatile for impeded installation situations such as multiple storey builds and obstructing window locations
HIDDEN ALUMINIUM FILTERS	Aesthetically pleasing, Dishwasher safe, Easy to remove, Effective in the removal of odours, Designed to trap grease, Long lasting
INDUCTION COUNTDOWN CONTROL	10 minute auto function used at the end of cooking to reduce condensation build up common to induction cooking.
FULL ELECTRONIC TOUCH CONTROL	Sleek, easy to clean touch controls in toughened glass
SAFETY SHUTDOWN	Stops unit being damaged due to miss installed filters from obstructing closing mechanism
MADE IN ITALY- German Made Motor	Units are designed specifically for the Australian market and manufactured in Italy by dedicated boutique specialist manufacturer
WARRANTY	Warranty is 4 years only when Sirius ducting is used. Sirius strongly recommend to use the correct ducting as to not void warranty and to achieve the ideal result

**Distributed by Arisit Pty Ltd**

40-44 Mark Anthony Drive, Dandenong South VIC 3175 Ph: 1300 762 219 Fax: 03 9768 0838 Website: [www.arisit.com](http://www.arisit.com)

# SDD2 EMTC 580

58CM DOWNDRAFT HOOD WITH WHITE GLASS PANEL



let's get  
**Sirius**  
with rangehood design

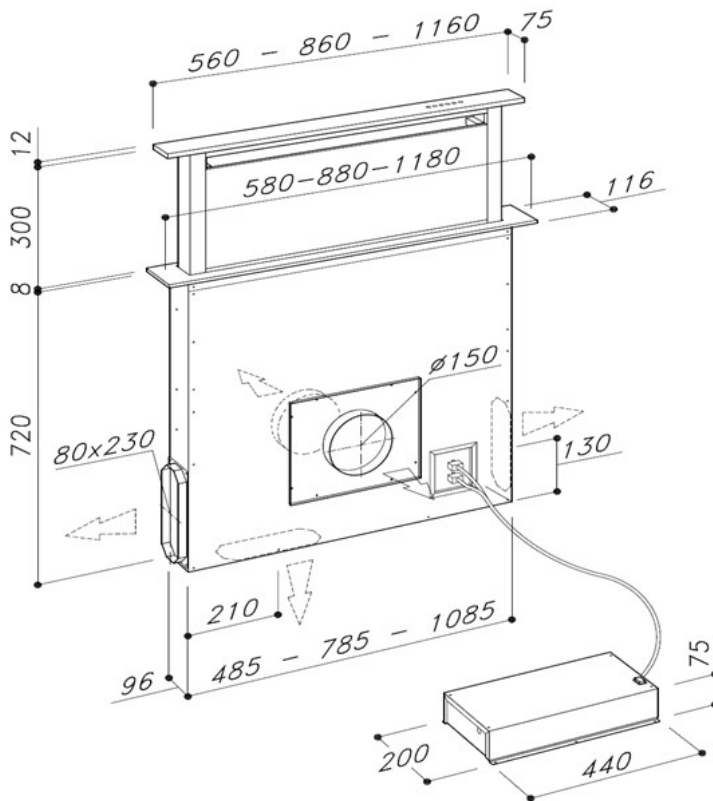

## WARNING!

Do not install below overhead cupboards as access if required in the case of a service call. The unit must be accessible to remove

### Technical Specifications:

MODEL	SDD2 EMTC 580 WH WITH WHITE GLASS PANEL
CONTROL PANEL	TOUCH CONTROL
MOTOR	SEM1 SEM2 SEM5 SEM10
EXTRACTION	1200m/3h
DUCTING DIAMETER	150mm
LIGHTS	N/A
FILTER	ALUMINIUM
ELECTRICAL REQUIREMENT	10A
PRODUCT DIMENSIONS	580 x 116 x 728 + 312
WARRANTY	3 YEARS - 4 YEARS WHEN SIRIUS DUCTING IS USED

WARNING: technical specifications and product sizes can be varied by the manufacturer, without notice. Cut outs for appliances should only be by physical product measurements. The above information is indicative only.

**Distributed by Arisit Pty Ltd**

40-44 Mark Anthony Drive, Dandenong South VIC 3175 Ph: 1300 762 219 Fax: 03 9768 0838 Website: [www.arisit.com](http://www.arisit.com)