

**SDD2 L EMTC 580**  
**58CM FLUSH DOWNDRAFT HOOD**



Let's get  
**Sirius**  
 with rangehood design



**SDD2 L EMTC 580**

**Features and Benefits:**

DOWNDRAFT WITH FLUSH FIT DESIGN	Perfect for island installation offering an alternative to bulky island hoods, Modern aesthetic, retractable for unrestricted vision, installed in bench making it versatile for impeded installation situations such as multiple storey builds & obstructing window locations
HIDDEN ALUMINIUM FILTERS	Aesthetically pleasing, Dishwasher safe, Easy to remove, Effective in the removal of odours, Designed to trap grease, Long lasting
FULL ELECTRONIC TOUCH CONTROL	10 minute auto function used at the end of cooking to reduce condensation build up common to induction cooking.
SAFETY SHUTDOWN	Sleek, easy to clean touch controls in toughened glass closing mechanism
MADE IN ITALY	Units are designed specifically for the Australian market and manufactured in Italy by
INBENCH DESIGN	Perfect for island installation – no need for dominating Island hood obstructing the view of and in your kitchen
VARIOUS MOTOR LOCATIONS	Motor can be located indoors up to 5-7 meters away from unit or an external/outdoor motor can be used.
MULTIPLE VENT OUTLETS	There are several outlet points located on the unit (see above arrows on diagram) for ease and flexibility of install options
WARRANTY	Warranty is 4 years only when Sirius ducting is used. Sirius strongly recommend to use the correct ducting as to not void warranty and to achieve the ideal result

**Distributed by Arisit Pty Ltd**

40-44 Mark Anthony Drive, Dandenong South VIC 3175 Ph: 1300 762 219 Fax: 03 9768 0838 Website: [www.arisit.com](http://www.arisit.com)

# SDD2 L EMTC 580

## 58CM FLUSH DOWNDRAFT HOOD

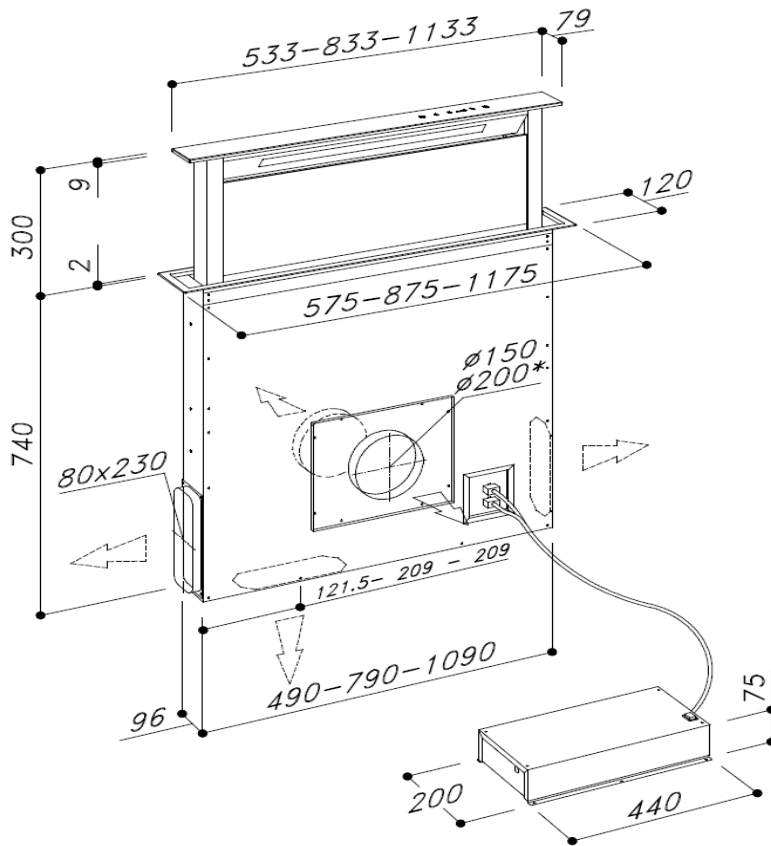

**WARNING!** Do not install below overhead cupboards as access is required in the case of a service call. The unit must be accessible to remove

### Technical Specifications:

MODEL	SDD2 L EMTC580
CONTROL PANEL	TOUCH CONTROL
MOTOR	SEM 1, SEM 2, SEM 10
EXTRACTION	1200M3/H
DUCTING DIAMETER	150mm
LIGHTS	1 x LED
FILTER	ALMUNUM MESH
ELECTRICAL REQUIREMENT	10A
PRODUCT DIMENSIONS	575 x 120 x 742 + 309
WARRANTY	3 YEARS - 4 YEARS WHEN SIRIUS DUCTING IS USED

WARNING: technical specifications and product sizes can be varied by the manufacturer, without notice. Cut outs for appliances should only be by physical product measurements. The above information is indicative only.

Distributed by Arisit Pty Ltd

40-44 Mark Anthony Drive, Dandenong South VIC 3175 Ph: 1300 762 219 Fax: 03 9768 0838 Website: www.arisit.com