

SL906 EM-L 1000

100CM UNDERMOUNT HOOD



let's get
Sirius
with rangehood design



SL906 EM-L 1000

Features and Benefits:

UNDERMOUNT DESIGN	Streamline, modern and unobtrusive design, potentially allows greater use of cupboard space above hob- Fits into Standard 300mm cabinetry
OFF BOARD MOTOR	Locating the motor away from the hood minimises noise in the kitchen up to 95% while still achieving maximum extraction, Motors can be installed up to 7 meters away with both indoor and external motors available making these the most versatile units on the market, no additional power required as motor is powered by a cable from the hood
LED Strip Lighting	Energy efficient, Better illumination of cooking area, Longer life span than standard globes or Halogen, Modern aesthetic
25MM COMMERCIAL STAINLESS STEEL BAFFLE FILTERS	Commercial design, Dishwasher safe, Designed for greatest air movement for maximum performance, Easy to fit and remove, Lifetime filters: last the life of the hood
INDUCTION COUNTDOWN CONTROL	10 minute auto function used at the end of cooking to reduce condensation build up common to induction cooking. 'C' shaped baffles eliminates moisture dripping onto cooking surface
LARGER DUCTING DIAMETER	Greater extraction and lower dB rating due to less air flow restriction
CLEAN FILTER INDICATOR	Takes the guessing game out of maintaining your hood
MADE IN ITALY	Units are designed specifically for the Australian market and manufactured in Italy by dedicated boutique specialist manufacturer
WARRANTY	Warranty is 4 years only when Sirius ducting is used. Sirius strongly recommend to use the correct ducting as to not void warranty and to achieve the ideal result

Distributed by Arisit Pty Ltd

40-44 Mark Anthony Drive, Dandenong South VIC 3175 Ph: 1300 762 219 Fax: 03 9768 0838 Website: www.arisit.com

SL906 EM-L 1000

100CM UNDERMOUNT HOOD



let's get
Sirius
with rangehood design

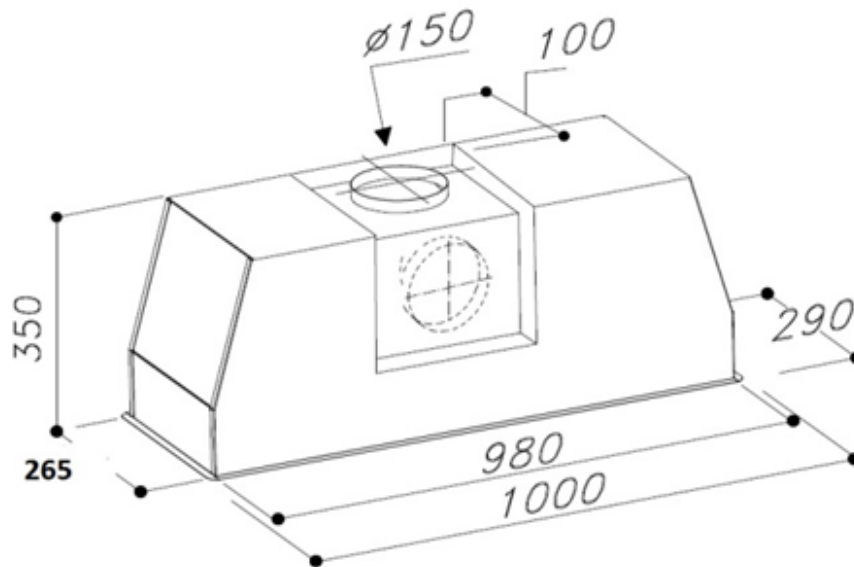

Technical Specifications:

MODEL	SL906 EM-L 1000
CONTROL PANEL	ELECTRONIC BUTTON CONTROL
MOTOR	SEM1 SEM2 SEM5
EXTRACTION	1200m/3h
DUCTING DIAMETER	150mm
LIGHTS	14W LED STRIP LIGHTING
FILTER	25mm STAINLESS STEEL BAFFLE
ELECTRICAL REQUIREMENT	10A
PRODUCT DIMENSIONS	1000 x 283 x 350
WARRANTY	3 YEARS - 4 YEARS WHEN SIRIUS DUCTING IS USED

WARNING: technical specifications and product sizes can be varied by the manufacturer, without notice. Cut outs for appliances should only be by physical product measurements. The above information is indicative only.

Distributed by Arisit Pty Ltd

40-44 Mark Anthony Drive, Dandenong South VIC 3175 Ph: 1300 762 219 Fax: 03 9768 0838 Website: www.arisit.com