

# SL EM 107 S 900

## 90CM CANOPY HOOD



let's get  
**Sirius**  
with rangehood design



## SL EM 107 S900

### Features and Benefits:

DESIGNER CANOPY RANGE	Sleek and Contemporary Design with superior power and performance
LED STRIP LIGHTING	Energy efficient with Better illumination of cooking area and a Longer life span than standard globes. Modern aesthetic Look
BAFFLE FILTERS	18/10 Grade stainless steel 25mm Baffle filters
INDUCTION COUNTDOWN CONTROL	10 minute auto function used at the end of cooking to reduce condensation build up and to remove cooking smells from the room
SEM MOTOR OPTIONS	SEM 1 or SEM 2, SEM 5
CLEAN FILTER INDICATOR	Takes the guessing game out of maintaining your hood. The lights will flash when the filters need cleaning
MADE IN ITALY	Units are designed specifically for the Australian market and manufactured in Italy by dedicated boutique specialist manufacturer
WARRANTY	Warranty is 4 years only when Sirius ducting is used. Sirius strongly recommend to use the correct ducting as to not void warranty and to achieve the ideal result

**Distributed by Arisit Pty Ltd**

40-44 Mark Anthony Drive, Dandenong South VIC 3175 Ph: 1300 762 219 Fax: 03 9768 0838 Website: [www.arisit.com](http://www.arisit.com)

# SL EM 107 S900

## 90CM CANOPY HOOD



let's get  
**Sirius**  
with rangehood design

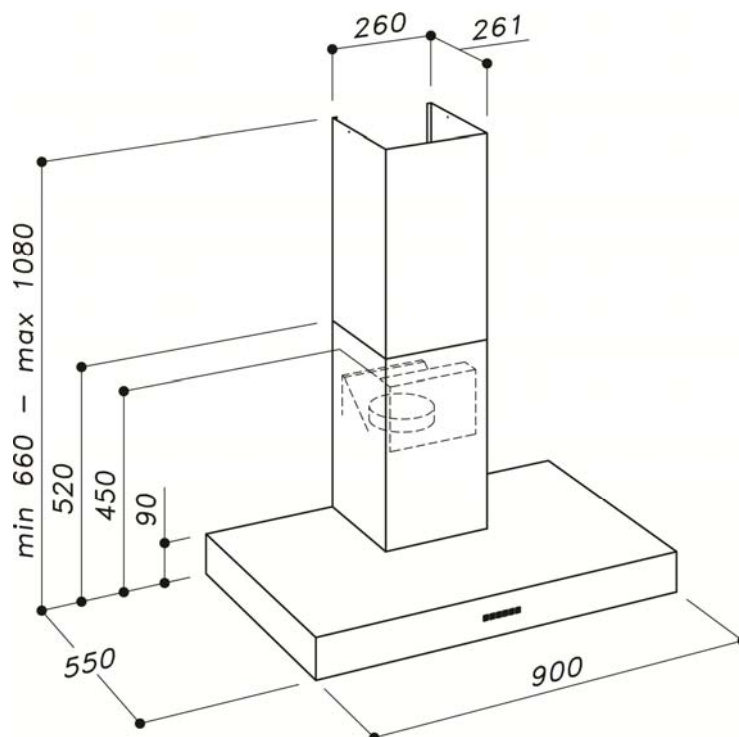

### Technical Specifications:

<b>MODEL</b>	SL EM 107 S900
<b>CONTROL PANEL</b>	ELECTRONIC CONTROL
<b>MOTOR</b>	SEM 1, SEM 2, SEM 5
<b>EXTRACTION</b>	1200 m3/h
<b>DUCTING DIAMETER</b>	150mm
<b>LIGHTS</b>	2 x 6W LED STRIP LIGHTING
<b>FILTER</b>	25mm BAFFLE FILTER
<b>ELECTRICAL REQUIREMENT</b>	10A
<b>PRODUCT DIMENSIONS</b>	900 x 550 x 660-1080
<b>WARRANTY</b>	3 YEARS - 4 YEARS WHEN SIRIUS DUCTING IS USED

WARNING: technical specifications and product sizes can be varied by the manufacturer, without notice. Cut outs for appliances should only be by physical product measurements. The above information is indicative only.

**Distributed by Arisit Pty Ltd**

40-44 Mark Anthony Drive, Dandenong South VIC 3175 Ph: 1300 762 219 Fax: 03 9768 0838 Website: [www.arisit.com](http://www.arisit.com)