

PENDANT RECIRCULATING RANGEHOOD - WALL MOUNTED

SLT-105



Pendant colours available	White (W), Black (B), Gold (G) (shown above), Copper (C)
---------------------------	--

Rangehood type	Wall mount pendant
Control	Remote control
Speed settings	4
Ducting	N/A (recirculating)
Extraction type	Filtering and recirculating
Motor	Single onboard aluminium
Filter	HP recirculating insert
Extraction	600m ³ /h
Noise	63 dBA
Lighting	LED Light
Induction Countdown Control	Yes
Electrical requirement	10A
Dimensions (motor/light) (mm)	W480 diameter x H460
Weight	18.5kg
Warranty	6 years



**INDUCTION
SAFE**



**RECIRCULATING
HOOD**



**REMOTE
CONTROL**



**SPEED
SETTINGS**



**SINGLE
ONBOARD
MOTOR**



**600m³/h
AIRFLOW**



LED LIGHT



**HANDCRAFTED
IN ITALY**

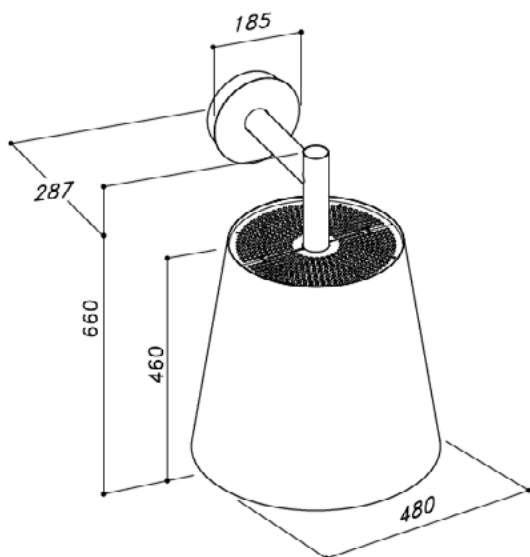

WARNING: technical specifications and product sizes can be varied by the manufacturer, without notice. Cut outs for appliances should only be by physical product measurements. The above information is indicative only.

Distributed by Arisit Pty Ltd