

SLT968 EM 1100MM CEILING CASSETTE



Let's get
Sirius
with rangehood design



SLT968 EM X – Stainless Steel

SLT968 EM WH – White

Features and Benefits:

CEILING CASSETTE DESIGN	Streamline, modern and unobtrusive design, Island solution, remote controlled for ease of use
LED STRIP LIGHTING	Energy efficient, Better illumination of cooking area, Longer life span than standard globes, Modern aesthetic
PERIMETRICAL EXTRACTION	Designed to increase airflow. Stainless steel panel with aluminium internal filter
INDUCTION COUNTDOWN CONTROL	10 minute auto function used at the end of cooking to reduce condensation build up and to remove cooking smells from the room
LARGER DUCTING DIAMETER	Greater extraction and lower dB rating due to less air flow restriction
CLEAN FILTER INDICATOR	Takes the guessing game out of maintaining your hood
MADE IN ITALY	Units are designed specifically for the Australian market and manufactured in Italy by dedicated boutique specialist manufacturer
WARRANTY	Warranty is 4 years only when Sirius ducting is used. Sirius strongly recommend to use the correct ducting as to not void warranty and to achieve the ideal result

Distributed by Arisit Pty Ltd

40-44 Mark Anthony Drive, Dandenong South VIC 3175 Ph: 1300 762 219 Fax: 03 9768 0838 Website: www.arisit.com

SLT968 EM 1100MM CEILING CASSETTE



let's get
Sirius
with rangehood design

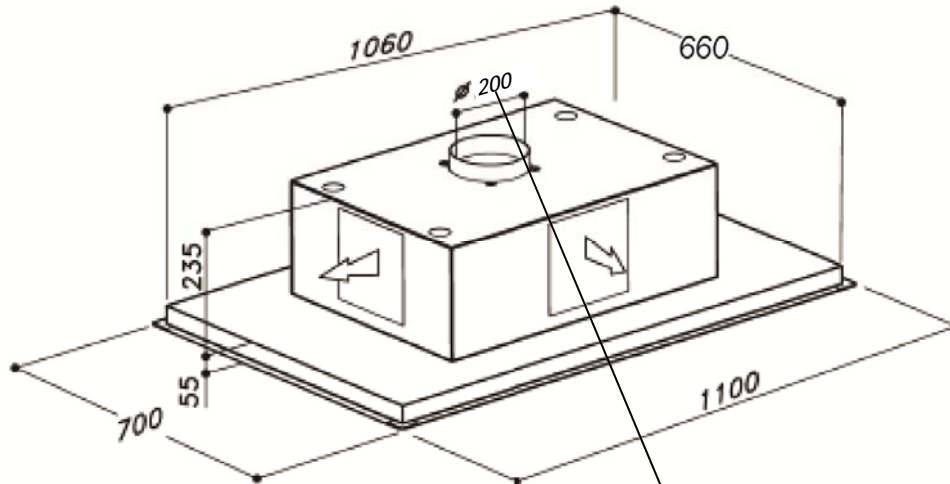

Unit must have 200mm ducting, or it will void WARRANTY.

Technical Specifications:

MODEL	SLT968 EM
CONTROL PANEL	REMOTE ELECTRONIC CONTROL
MOTOR	SEM 7, SEM 8
EXTRACTION	2300 m ³ /h (SEM 7), 1650 m ³ /h (SEM 8)
DUCTING DIAMETER	200 mm
LIGHTS	LED STRIP LIGHTING
FILTER	INTERNAL ALUMINIUM
ELECTRICAL REQUIREMENT	10A
PRODUCT DIMENSIONS	1100 x 700 x 235 + 55
WARRANTY	3 YEARS - 4 YEARS WHEN SIRIUS DUCTING IS USED

WARNING: technical specifications and product sizes can be varied by the manufacturer, without notice. Cut outs for appliances should only be by physical product measurements. The above information is indicative only.

Distributed by Arisit Pty Ltd

40-44 Mark Anthony Drive, Dandenong South VIC 3175 Ph: 1300 762 219 Fax: 03 9768 0838 Website: www.arisit.com