

900mm ONBOARD CANOPY RANGEHOOD BLACK GLASS FASCIA

SLTC 107 G 900



Rangehood type	Canopy
Control	Electronic Touch control
Speed settings	4
Ducting diameter	150mm
Extraction type	Onboard motor
Motor*	Onboard aluminium motor
Extraction	1020m ³ /h
Filter	25mm stainless steel baffle
Lighting	2 x 6W LED strips
Induction Countdown Control	Yes
Noise level	58dBA
Electrical requirement	10A
Dimensions (mm)	W900 x D550 x H660-1080
Warranty	3 years (6 years when Sirius ducting is used)



SINGLE MOTOR



25mm BAFFLE FILTERS

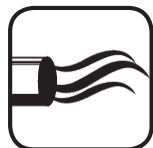

1020m³/h AIRFLOW



INDUCTION SAFE



LED LIGHTING



HANDCRAFTED IN ITALY

Ducting options

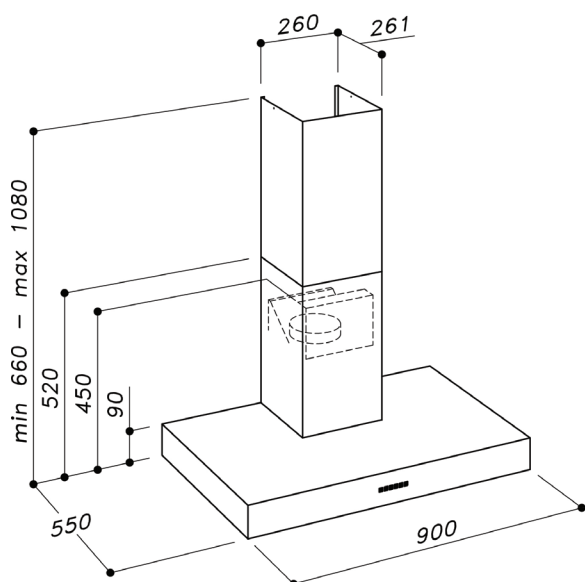

*Outdoor offboard motors have a marine grade finish as standard for added resistance to coastal weather elements.

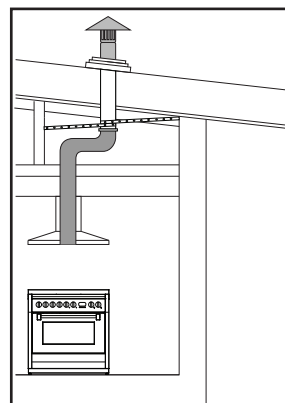

Roof ducted

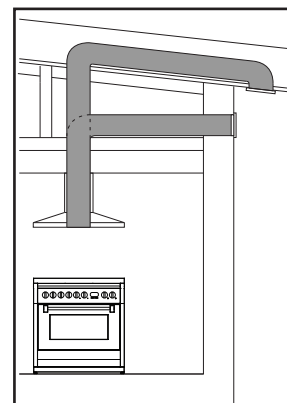

Eave or Wall ducted

- Use semi-rigid or rigid ducting, not fully flexible foil ducting.
- Fewer bends means a quieter and more powerful extraction
- Extra 3 years warranty when Sirius ducting is used (total 6 years)
- See [support page](#) on Sirius website for installation videos and FAQs

WARNING: technical specifications and product sizes can be varied by the manufacturer, without notice. Cut outs for appliances should only be by physical product measurements. The above information is indicative only.

Distributed by Arisit Pty Ltd

40-50 Mark Anthony Drive, Dandenong South VIC 3175

Ph: 1300 762 219

Fax: 03 9768 0838

Website: www.arisit.com

www.siriusbrand.com