

# 900mm ONBOARD CANOPY RANGEHOOD - BLACK FINISH

SLTC 97 900



|                             |   |
|-----------------------------|---|
| Rangehood type              | Canopy  |
| Control                     | Electronic control                            |
| Speed settings              | 4   |
| Ducting diameter            | 150mm   |
| Extraction type             | Onboard motor                                 |
| Motor                       | Single aluminium motor                        |
| Extraction                  | 1020m <sup>3</sup> /h                         |
| Filter                      | 10mm stainless steel baffle                   |
| Lighting                    | 2 x 6W LED Strips                             |
| Induction Countdown Control | Yes   |
| Noise level                 | 59dB  |
| Electrical requirement      | 10A   |
| Dimensions (mm)             | W900 x D550 x H810-1340                       |
| Warranty                    | 3 years (6 years when Sirius ducting is used) |



**SINGLE MOTOR**



**10mm BAFFLE FILTERS**

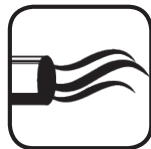

**1020m<sup>3</sup>/h AIRFLOW**



**INDUCTION SAFE**



**LED LIGHTING**



**HANDCRAFTED IN ITALY**

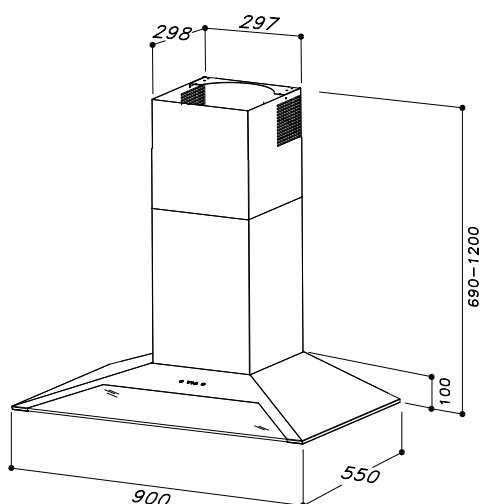

## Ducting options

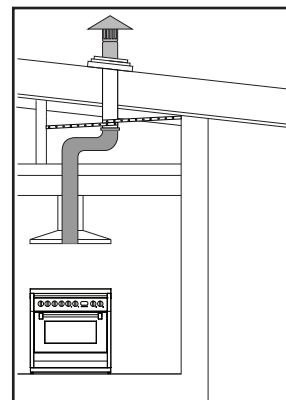

Roof ducted

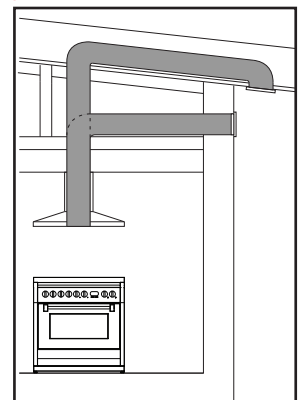

Eave or Wall ducted

- Use semi-rigid or rigid ducting, not fully flexible foil ducting.
- Fewer bends means a quieter and more powerful extraction.
- Extra 3 years warranty when Sirius ducting is used (total 6 years).
- See [support page](#) on Sirius website for installation videos and FAQs.

WARNING: technical specifications and product sizes can be varied by the manufacturer, without notice. Cut outs for appliances should only be by physical product measurements. The above information is indicative only.

Distributed by Arisit Pty Ltd